

数据仅供参考：如有修改，恕不通知。
版权所有，盗版必究。

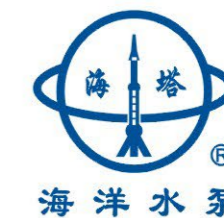

▶ CDL、CDLF系列立式多级离心泵
CDL, CDLF series vertical multistage centrifugal pump

上海海洋泵阀制造有限公司
SHANGHAI SEA PUMP & VALVE MFG CO.,LTD.

地址：上海市松江区玉佳西路84号
电话：0086-021-63546554 63803848
传真：0086-021-33550508
<http://www.sea-pump.com>

上海海洋泵阀制造有限公司
SHANGHAI SEA PUMP & VALVE MFG CO.,LTD.



企业简介⁺ ABOUTUS

上海海洋泵阀制造有限公司成立于1994年，并于2002年正式更名为上海海洋泵阀制造有限公司，注册资金1050万，坐落于上海市生产基地的松江区。本公司是专业生产水泵、生活消防成套智能控制给水设备及水泵智能电气控制设备的大型股份制企业，在全国各地设有二十多个办事处。遍布全国各大中城市，为海洋创造快速的售后服务打下坚实的基础。

海洋泵阀始终致力于科技和管理的创新，开发出适用于工矿企业、城市供水、城市污水处理、农田排灌、石油化工、高层建筑供水消防、空调供暖等各行各业的用泵。产品发往全国各地，以可靠的性能和合理的价格受到广大用户的青睐。

海洋泵阀目前能生产30多个系列，1000多种规格，适用于工矿企业、城市供水、城市污水处理、石油化工、农业排灌等行业的用泵。主导产品XBD系列高层建筑给水泵被国家建设部批准为工程建设推荐产品。

海洋泵阀秉承“产品决定前途、质量决定命运、效益决定兴衰、素质决定成败”的经营理念，不断开拓锐意进取，铸就客户百分之百满意工程：ISO9001-2000质量体系品质保证，以及快速反应售后服务和定期咨询双重服务保障。海洋泵阀以人为本，以诚待人，以国际质量管理体系为管理标准不断拓展相关领域——承揽环保工程、提供成套生活供水和消防设施，制造出优质、高效、节能的国际产品，服务于人类建设美好家园！

公司以一流的管理、一流的产品、一流的服务，赢得了广大用户的信赖和好评。

产品目录⁺ CONTENTS



总体数据

型号含义、产品范围

1

泵、电机、运转条件、CDLF2; 4材料

2

CDLF8; 16; 32; 42; 65; 85; 120; 150; 200材料

3

最大进口压力、最大工作压力、最大流量、最小流量

4

泵规格、效率、轴封、工作压力和进口压力、产品应用、最小进口压力

5

性能曲线说明

6

性能曲线、技术数据

CDLF2

7

CDLF4

9

CDLF8

11

CDLF16

13

CDLF32

15

CDLF42

17

CDLF65

19

CDLF85

21

CDLF120

23

CDLF150

25

CDLF200

27

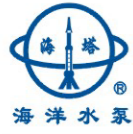

CDL、CDLF系列立式多级离心泵
CDL, CDLF series vertical multistage centrifugal pump

CDLF8;CDLF16

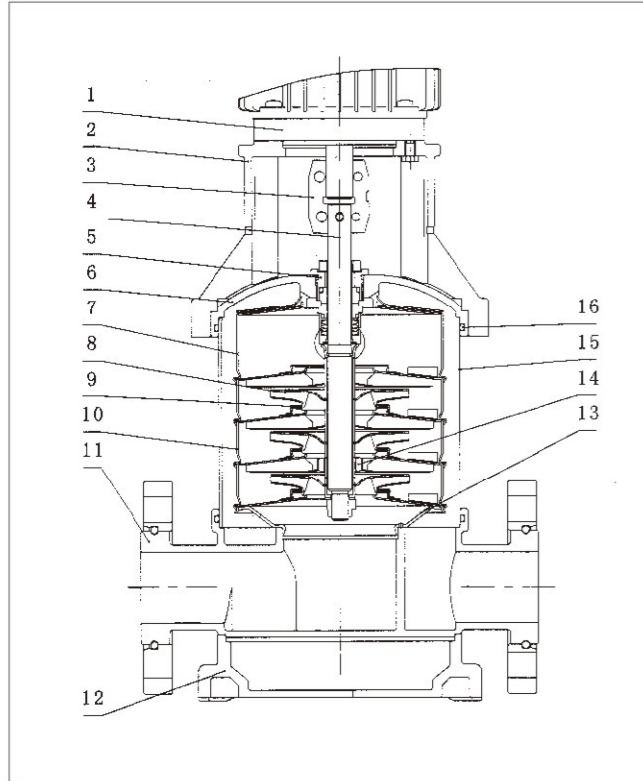

CDLF32;42;64;85;120;150

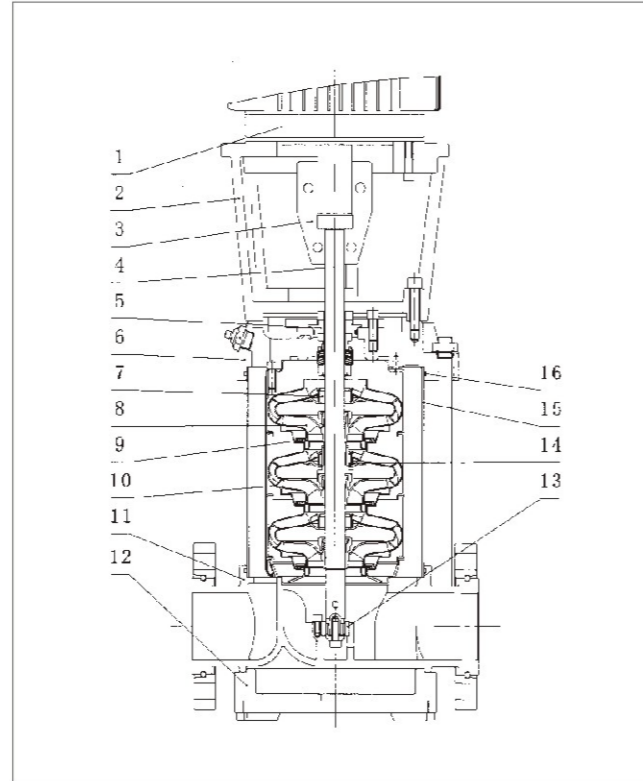

材料: CDLF

序列	名称	材料	AISI/ASTM
1	电机		-
2	电机座	铸铁	ASTM25B
3	联轴器	碳钢	-
4	泵轴	不锈钢	AISI304/316L
5	机械密封	多种材料*	-
6	机封衬盖	不锈钢	AISI304/316
7	出水导叶	不锈钢	AISI304/316
8	叶轮	不锈钢	AISI304/316
9	颈环	石墨填充PTFE	-
10	导叶	不锈钢	AISI304/316
11	进出水段	不锈钢	AISI304/316
12	底座	铸铁	ASTM25B
13	进水导叶	不锈钢	AISI304/316
14	轴承	碳化钨	-
15	外套筒	不锈钢	AISI304/316
16	外套筒O型圈	EPDM或FKM	-

*有不锈钢件及橡胶件
-非不锈钢件或没有提供参照物

序列	名称	材料	AISI/ASTM
1	电机		-
2	电机座	铸铁	ASTM25B
3	联轴器	碳钢	-
4	泵轴	不锈钢	AISI304/316L
5	机械密封	多种材料*	-
6	机封衬盖	不锈钢	AISI304/316
7	出水导叶	不锈钢	AISI304/316
8	叶轮	不锈钢	AISI304/316
9	颈环	石墨填充PTFE	-
10	导叶	不锈钢	AISI304/316
11	进出水段	不锈钢	AISI304/316
12	底座	铸铁	ASTM25B
13	进水导叶	不锈钢	AISI304/316
14	轴承	碳化钨	-
15	外套筒	不锈钢	AISI304/316
16	外套筒O型圈	EPDM或FKM	-

*有不锈钢件及橡胶件
-非不锈钢件或没有提供参照物

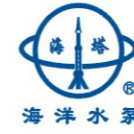

CDL、CDLF系列立式多级离心泵
CDL, CDLF series vertical multistage centrifugal pump

最大进口压力

下表为最大进口压力，但是，实际的进口压力与闭阀压力必须低于最大允许工作压力

泵型号	最大进口压力 (bar)
CDLF2-2	6
CDLF2-3~CDLF2-11	10
CDLF2-12~CDLF2-26	15
CDLF4-2	6
CDLF4-3~CDLF4-10	10
CDLF4-11~CDLF4-22	15
CDLF8-2/1~CDLF8-6	6
CDLF8-7~CDLF8-20	10
CDLF16-2~CDLF16-3	6
CDLF16-4~CDLF16-16	10
CDLF32-1/1~CDLF32-2/2	3
CDLF32-2~CDLF32-4	4
CDLF32-5/2~CDLF32-10	10
CDLF32-11/2~CDLF32-14	15
CDLF42-1/1	3
CDLF42-1~CDLF42-2	4
CDLF42-3/2~CDLF42-4	10
CDLF42-5/2~CDLF42-13/2	15
CDLF65-1/1~CDLF65-2/2	4
CDLF65-2/1~CDLF65-3/1	10
CDLF65-3~CDLF6-8/1	15
CDLF65-1/1~CDLF85-8/1	4
CDLF85-2/2~CDLF85-2	10
CDLF85-3/3~CDLF85-6	15
CDLF120-1/1~CDLF120-8/1	20
CDLF120-2/2~CDLF120-2	20
CDLF120-3/2~CDLF120-6	20

工作压力和进口压力

工作压力和进口压力不能单独考虑，必须同时考虑并且满足。比如：

例1:

泵型号: CDLF4-16
最大工作压力: 25bar
最大进口压力: 10bar
闭阀压力: 16.4bar, 见CDLF4-16性能曲线

在这种条件下，在进口压力为6bar时不能启动该泵，因为10+16.4=26.4bar高于最大允许工作压力25bar，所以该泵进口压力必须低于8.6bar。实际允许进口压力为25-16.4=8.6bar

例2:

泵型号: CDLF4-2
最大工作压力: 16bar
最大进口压力: 6bar
闭阀压力: 2.0bar, 见CDLF4-2性能曲线。

在这种条件下，在进口压力为6bar时可以启动该泵。因为其闭阀压力为2.0bar，则该泵的工作压力为6+2.0=8bar。相反地，泵的最大工作压力将被限制在8bar，因为更高的工作压力将高于进口压力6bar

最大流量

为防止泵在运行时过载而造成损坏和其他损失，本泵有其最大流量限制，详见后页的泵性能曲线的推荐用粗线段所示

最大流量

为防止过热造成的危害，泵不能低于在最小流量下运行。

型号泵	最小流量	
	70℃以下	70℃~120℃
CDLE2	0.2m³/h	0.5m³/h
CDLE4	0.4m³/h	1.0m³/h
CDLE8	0.8m³/h	2.0m³/h
CDLE16	1.6m³/h	4.0m³/h
CDLE32	3.2m³/h	8.0m³/h

友情提醒，为确保安全使用本泵，请确认泵已经在泵性能曲线的推荐用粗线段范围内使用！



CDL、CDLF系列立式多级离心泵
CDL, CDLF series vertical multistage centrifugal pump

泵规格

泵型的选取应根据下述情况选择：
*使用点的流量压力；
*高度差带来的压力损失；
*管路摩擦损失；
*在工况点的最佳效率。

效率

如果泵总是在同一工作点运行，应选择的泵其工作点在最高效率点；如果小号或控制运行，选泵时应使最高效率点位于工作范围内。

轴封

轴封选择必须考虑以下因素：
*介质类型
*介质温度
*最大压力

工作压力和进口压力

检查压力条件是否满足要求
*最大工作压力；
*最大进口压力。

产品应用

典型应用	增压
供水	流程水系统
水厂的过滤与输送	高压冲洗系统
主管增压	消防系统
高层建筑增压	输送
工业给水增压	冷却和空调系统
水处理	锅炉给水和冷凝水系统
高压过滤系统	酒和酒精
反渗透系统	灌溉
软化、电解、除盐系统、	土地灌溉
蒸馏系统	喷灌
	滴灌

最小进口压力

在下列情况下应计算进口压力：
*液体温度较高；
*流量明显比额定值打；
*液体所需的吸程很大；
*进口管路很长；
*进口条件比较差。
泵最大吸程“H”可参考下图，按下式计算
 $H = Pb \times 10.2 - NPSH - H_f - H_v - H_s$

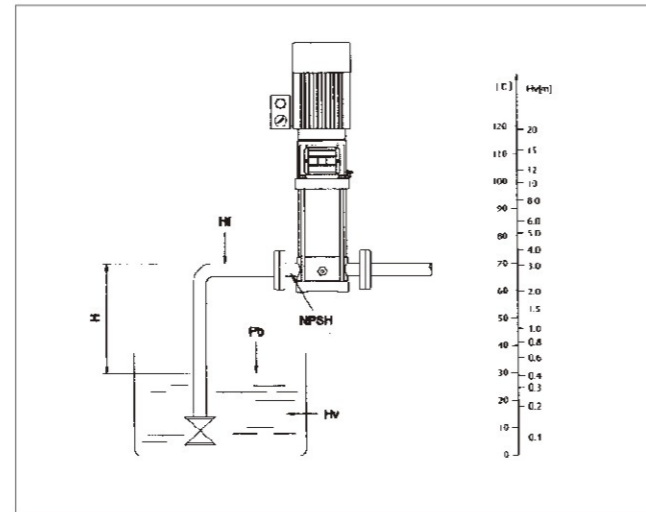

Pb=大气压力 (bar)，大气压力可设定为1bar。
在闭式系统中，Pb系统压力 (bar)
NPSH=净正吸头 (m)，从NPSH曲线上泵可能的最大流量处读取。
Hf=人口的管路损失 (m)，以泵可能的最大流量时计算。
Hv=汽化压力 (m)，可从上图汽化压力尺中读取。
Hs=安全余量 (m)，可取最小0.5m水头。
如计算所得“H”为正值，则泵可能在最大吸程“H”情况下运行；如计算所得“H”为负值，则必须有一最小进口压力“H”m的水头。

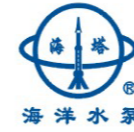

CDL、CDLF系列立式多级离心泵
CDL, CDLF series vertical multistage centrifugal pump

性能曲线说明

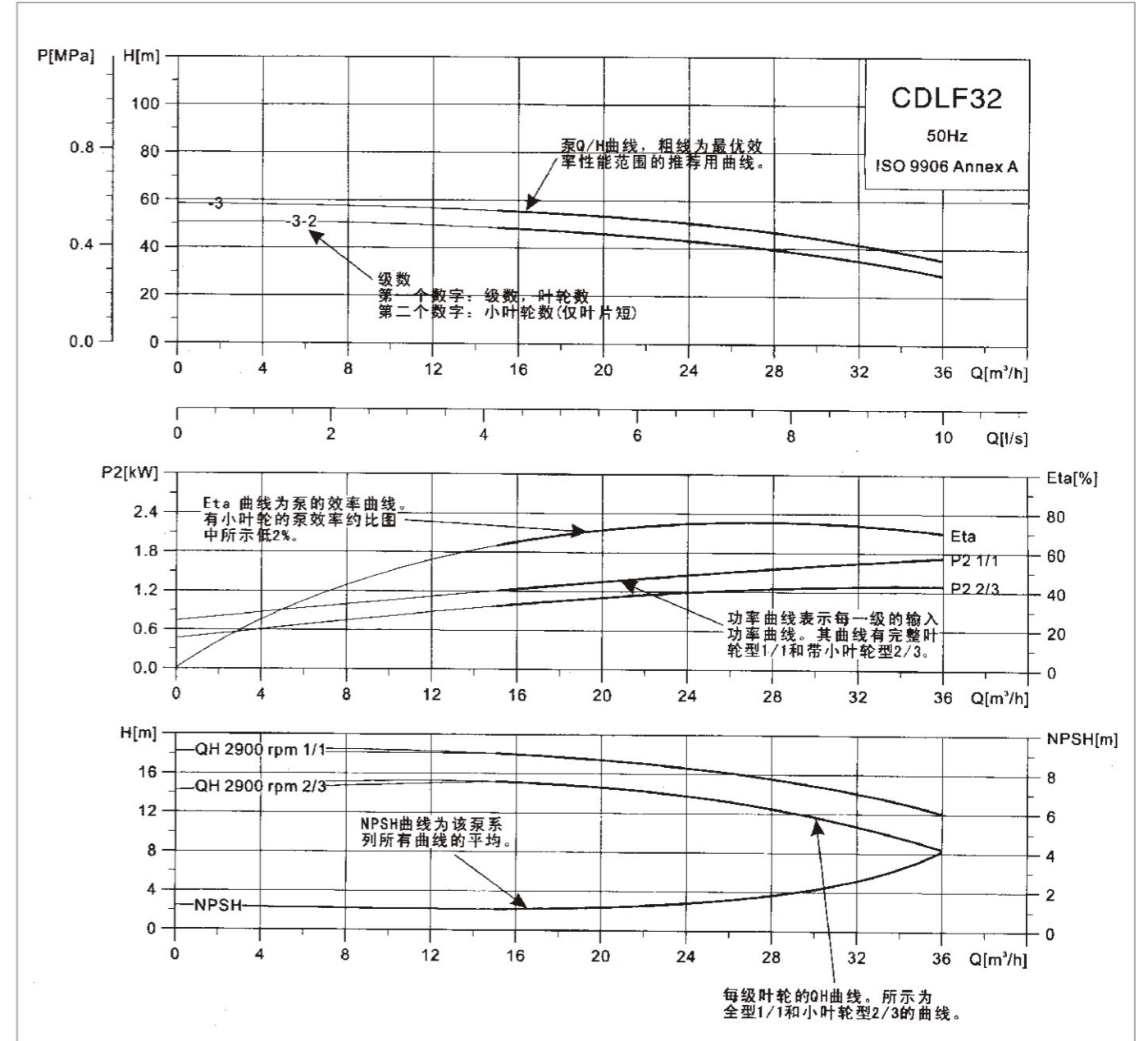

性能曲线说明

- 下述说明适用于后面所示的曲线：
- 1.所有曲线都是基于3x380-415、50HZ，电机在恒速2900rpm的测量值。
 - 2.测量采用20℃，不含有空气的水。
 - 3.曲线适用于运动粘度 $\nu = 1\text{mm}^2/\text{s}$ 的介质。
 - 4.曲线偏差按ISO9906, AnnexA。
 - 5.泵的使用请参照性能曲线推荐用粗线段，为防止流量过小或过大而发生危险。

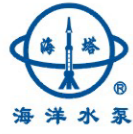

CDL、CDLF系列立式多级离心泵
CDL, CDLF series vertical multistage centrifugal pump

尺寸图

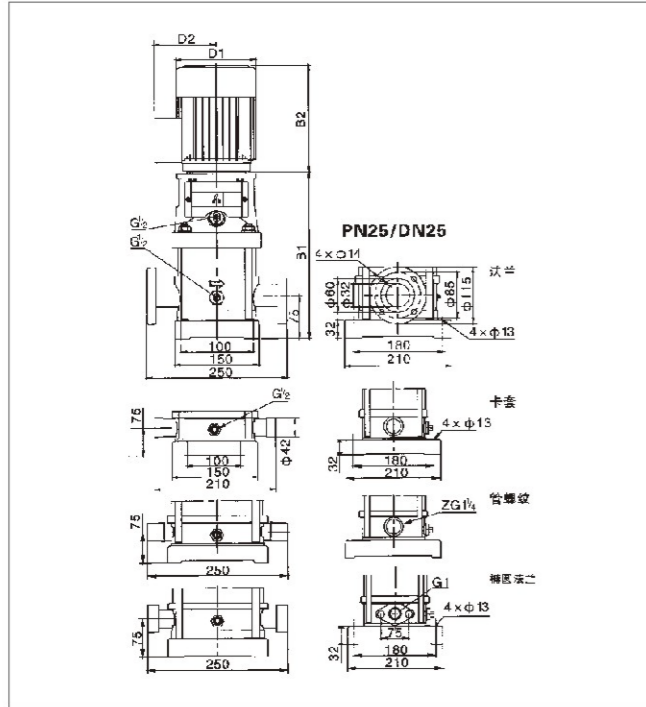

尺寸和重量

泵型号	尺寸 (mm)					重量 (kg)
	B1	B2	B1+B2	D1	D2	
CDLF2-20	261		471			20
CDLF2-30	279	210	489	148	117	21
CDLF2-40	297		507			22
CDLF2-50	315		525			23
CDLF2-60	343		588			26
CDLF2-70	361		606			27
CDLF2-80	379	245	624	170	142	28
CDLF2-90	397		642			29
CDLF2-100	415		660			30
CDLF2-110	433		678			31
CDLF2-120	461		751			33
CDLF2-130	479		769			34
CDLF2-140	497		787			35
CDLF2-150	515		805			36
CDLF2-160	533	290	823	190	155	37
CDLF2-170	551		841			38
CDLF2-180	569		859			39
CDLF2-190	587		877			40
CDLF2-200	605		895			41
CDLF2-210	623		913			42
CDLF2-220	641		931			43
CDLF2-230	669		984			45
CDLF2-240	687	315	1002	197	165	48
CDLF2-250	705		1020			50
CDLF2-260	723		1038			52

注：表格中所示B1尺寸为DIN法兰型泵座的尺寸，其余类型泵座的B1尺寸，在此尺寸上减去25。

电气数据3x380-415v

泵型号	电机		功率因素COSφ
	千瓦kw	马力hp	
CDLF2-20	0.37	0.50	0.81
CDLF2-30	0.37	0.50	0.81
CDLF2-40	0.55	0.75	0.82
CDLF2-50	0.55	0.75	0.82
CDLF2-60	0.75	1.0	0.83
CDLF2-70	0.75	1.0	0.83
CDLF2-80	1.1	1.5	0.85
CDLF2-90	1.1	1.5	0.85
CDLF2-100	1.1	1.5	0.85
CDLF2-110	1.1	1.5	0.85
CDLF2-120	1.5	2.0	0.84
CDLF2-130	1.5	2.0	0.84
CDLF2-140	1.5	2.0	0.84
CDLF2-150	1.5	2.0	0.84
CDLF2-160	2.2	3.0	0.84
CDLF2-170	2.2	3.0	0.84
CDLF2-180	2.2	3.0	0.84
CDLF2-190	2.2	3.0	0.84
CDLF2-200	2.2	3.0	0.84
CDLF2-210	2.2	3.0	0.84
CDLF2-220	2.2	3.0	0.84
CDLF2-230	3.0	4.0	0.87
CDLF2-240	3.0	4.0	0.87
CDLF2-250	3.0	4.0	0.87
CDLF2-260	3.0	4.0	0.87

流量扬程

泵型号	流量Q (转数n≈2900)							
	M³/h	1.0	1.2	1.6	2.0	2.4	2.8	3.2
CDLF2-20		18	17	16	15	14	12	10
CDLF2-30		27	26	24	22	20	18	15
CDLF2-40		36	35	33	30	26	24	17
CDLF2-50		45	43	40	37	33	30	24
CDLF2-60		53	52	50	45	40	36	30
CDLF2-70		63	61	57	52	47	41	35
CDLF2-80		71	69	65	59	54	47	40
CDLF2-90		80	78	73	67	61	54	45
CDLF2-100		89	86	81	74	67	59	49
CDLF2-110		98	95	89	82	73	64	54
CDLF2-120		107	103	97	90	81	71	59
CDLF2-130		116	114	106	98	89	78	65
CDLF2-140		125	122	114	105	94	84	69
CDLF2-150		134	130	123	112	100	90	73
CDLF2-160		143	139	131	120	107	96	80
CDLF2-170		152	148	139	128	114	102	86
CDLF2-180		161	157	148	136	121	108	91
CDLF2-190		170	165	156	143	127	113	95
CDLF2-200		179	174	164	150	134	119	100
CDLF2-210		188	183	172	157	141	124	105
CDLF2-220		197	192	180	165	148	130	110
CDLF2-230		205	201	188	173	155	137	115
CDLF2-240		214	210	197	181	163	144	120
CDLF2-250		225	219	205	189	170	151	127
CDLF2-260		234	228	214	198	178	158	130



CDL、CDLF系列立式多级离心泵
CDL, CDLF series vertical multistage centrifugal pump

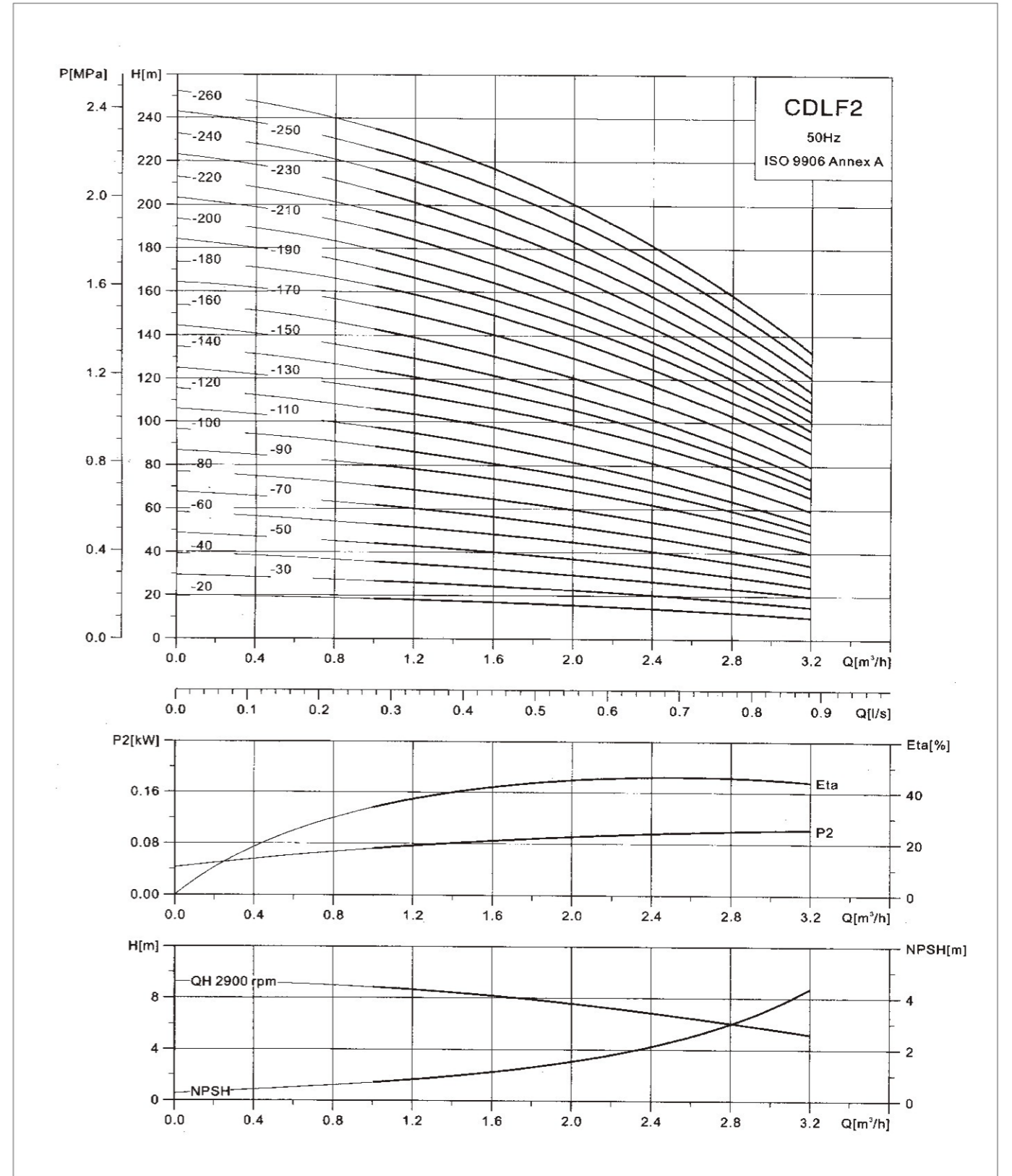

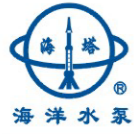

CDL、CDLF系列立式多级离心泵
CDL, CDLF series vertical multistage centrifugal pump

尺寸图

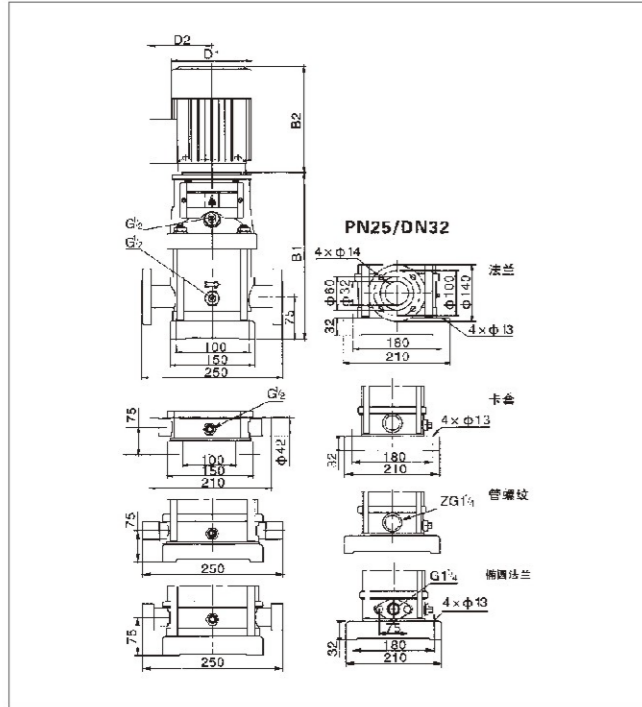

尺寸和重量

泵型号	尺寸 (mm)					重量 (kg)
	B1	B2	B1+B2	D1	D2	
CDLF4-20	297	210	489	148	117	20
CDLF4-30	306		516			21
CDLF4-40	343		588			23
CDLF4-50	370		615			24
CDLF4-60	397	245	942	170	142	26
CDLF4-70	434		724			28
CDLF4-80	461		751			29
CDLF4-90	488		778			31
CDLF4-100	515	290	805	190	155	32
CDLF4-110	542		832			34
CDLF4-120	569		859			35
CDLF4-130	606		921			36
CDLF4-140	633	315	948	197	165	38
CDLF4-150	660		975			39
CDLF4-160	687		1002			40
CDLF4-170	714		1049			42
CDLF4-180	741	335	1074	230	188	43
CDLF4-190	768		1103			46
CDLF4-200	795		1130			47
CDLF4-210	822		1157			49
CDLF4-220	849		1184			50

注：表格中所示B1尺寸为DIN法兰型泵座的尺寸，其余类型泵座的B1尺寸，在此尺寸上减去25。

电气数据3x380-415v

泵型号	电机		功率因素COSφ
	千瓦kw	马力hp	
CDLF4-20	0.37	0.50	0.81
CDLF4-30	0.55	0.75	0.82
CDLF4-40	0.75	1.0	0.83
CDLF4-50	1.1	1.5	0.85
CDLF4-60	1.1	1.5	0.85
CDLF4-70	1.5	2.0	0.84
CDLF4-80	1.5	2.0	0.84
CDLF4-90	2.2	3.0	0.84
CDLF4-100	2.2	3.0	0.84
CDLF4-110	2.2	3.0	0.84
CDLF4-120	2.2	3.0	0.84
CDLF4-130	3.0	4.0	0.87
CDLF4-140	3.0	4.0	0.87
CDLF4-150	3.0	4.0	0.87
CDLF4-160	3.0	4.0	0.87
CDLF4-170	4.0	5.5	0.88
CDLF4-180	4.0	5.5	0.88
CDLF4-190	4.0	5.5	0.88
CDLF4-200	4.0	5.5	0.88
CDLF4-210	4.0	5.5	0.88
CDLF4-220	4.0	5.5	0.88

流量扬程

泵型号	流量Q (转数n≈2900)						
	M³/h	2.0	3.0	4.0	5.0	6.0	7.0
CDLF4-20	扬程 H (m)	18	17	15	13	10	8
CDLF4-30		27	26	24	20	18	14
CDLF4-40		36	34	32	27	24	18
CDLF4-50		45	43	40	34	31	23
CDLF4-60		54	52	48	41	37	28
CDLF4-70		63	61	56	48	43	34
CDLF4-80		72	70	64	55	50	38
CDLF4-90		81	78	72	63	56	44
CDLF4-100		90	87	81	71	62	50
CDLF4-110		99	95	88	78	68	53
CDLF4-120		108	104	95	85	75	57
CDLF4-130		117	113	103	93	82	63
CDLF4-140		126	122	112	101	89	69
CDLF4-150		135	131	120	108	95	73
CDLF4-160		144	140	129	115	101	78
CDLF4-170		153	149	137	122	108	83
CDLF4-180		162	158	145	129	115	89
CDLF4-190		171	168	153	137	122	95
CDLF4-200		180	176	161	144	127	99
CDLF4-210		190	184	169	152	132	103
CDLF4-220		200	192	178	160	138	108

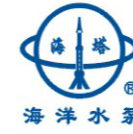

CDL、CDLF系列立式多级离心泵
CDL, CDLF series vertical multistage centrifugal pump

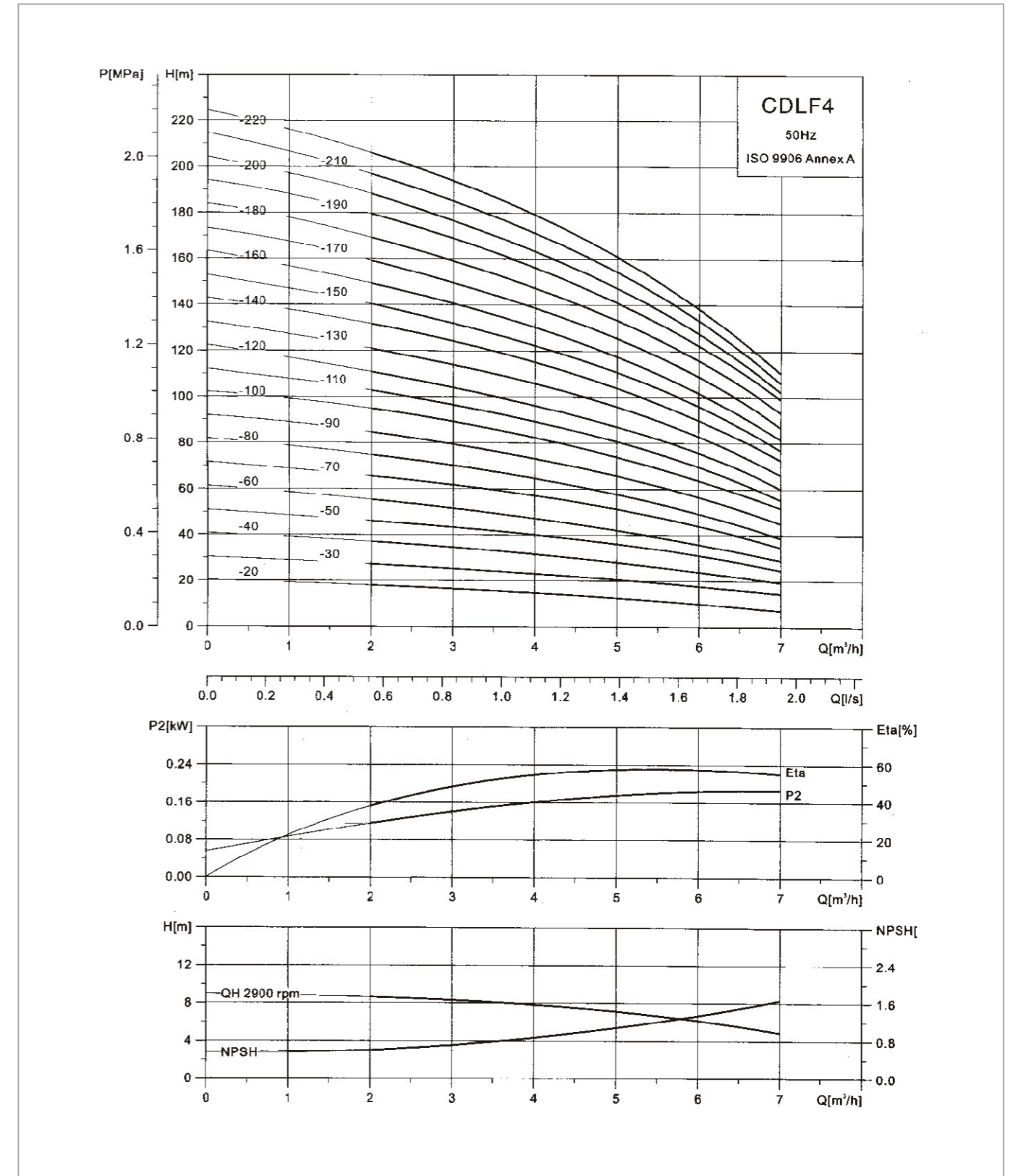

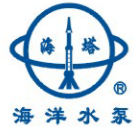

CDL、CDLF系列立式多级离心泵
CDL, CDLF series vertical multistage centrifugal pump

尺寸图

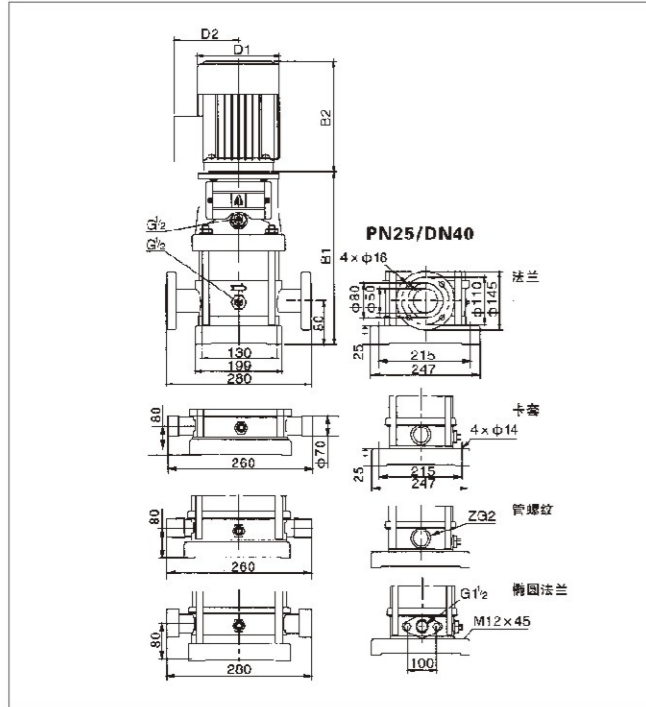

尺寸和重量

泵型号	尺寸 (mm)					重量 (kg)
	B1	B2	B1+B2	D1	D2	
CDLF8-20	364	245	609	170	142	35
CDLF8-30	394		636			35
CDLF8-40	434	290	724	190	155	45
CDLF8-50	464		754			50
CDLF8-60	494	315	784	197	165	50
CDLF8-70	534		849			55
CDLF8-80	564	335	879	230	188	55
CDLF8-90	594		929			55
CDLF8-100	624	430	959	260	108	55
CDLF8-110	654		989			60
CDLF8-120	684	430	1019	260	108	60
CDLF8-130	734		1164			85
CDLF8-140	764	430	1194	260	108	85
CDLF8-150	794		1224			85
CDLF8-160	824	430	1254	260	108	85
CDLF8-170	854		1284			90
CDLF8-180	884	430	1314	260	108	90
CDLF2-190	914		1344			90
CDLF2-200	944	1374	90			

电气数据3x380-415v

泵型号	电机		功率因素COSφ
	千瓦kw	马力hp	
CDLF8-20	0.75	1.0	0.83
CDLF8-30	1.1	1.5	0.85
CDLF8-40	1.5	2.0	0.84
CDLF8-50	2.2	3.0	0.84
CDLF8-60	2.2	3.0	0.84
CDLF8-70	3.0	4.0	0.87
CDLF8-80	3.0	4.0	0.87
CDLF8-90	4.0	5.5	0.88
CDLF8-100	4.0	5.5	0.88
CDLF8-110	4.0	5.5	0.88
CDLF8-120	4.0	5.5	0.88
CDLF8-130	5.5	7.5	0.88
CDLF8-140	5.5	7.5	0.88
CDLF8-150	5.5	7.5	0.88
CDLF8-160	5.5	7.5	0.88
CDLF8-170	7.5	10	0.88
CDLF8-180	7.5	10	0.88
CDLF2-190	7.5	10	0.88
CDLF2-200	7.5	10	0.88

流量扬程

泵型号	流量Q (转数n≈2900)							
	M³/h	6	7	8	9	10	11	12
CDLF8-20	20	19	18	17	16	14	13	
CDLF8-30	30	29	28	26	24	21	19	
CDLF8-40	40	38	36	34	32	28	26	
CDLF8-50	50	48	45	42	40	36	32	
CDLF8-60	60	57	54	51	48	43	39	
CDLF8-70	70	68	64	61	57	50	45	
CDLF8-80	80	77	73	69	65	58	52	
CDLF8-90	90	87	83	79	72	66	60	
CDLF8-100	100	97	92	87	81	73	65	
CDLF8-110	110	106	101	96	88	80	72	
CDLF8-120	120	116	111	104	92	87	78	
CDLF8-130	130	126	119	114	105	95	84	
CDLF8-140	141	136	130	122	113	102	92	
CDLF8-150	150	145	138	131	121	111	100	
CDLF8-160	161	156	148	139	130	118	106	
CDLF8-170	170	165	156	149	138	126	113	
CDLF8-180	182	175	167	157	146	134	120	
CDLF2-190	190	184	175	166	154	142	128	
CDLF2-200	202	195	186	175	163	150	135	

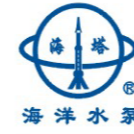

CDL、CDLF系列立式多级离心泵
CDL, CDLF series vertical multistage centrifugal pump

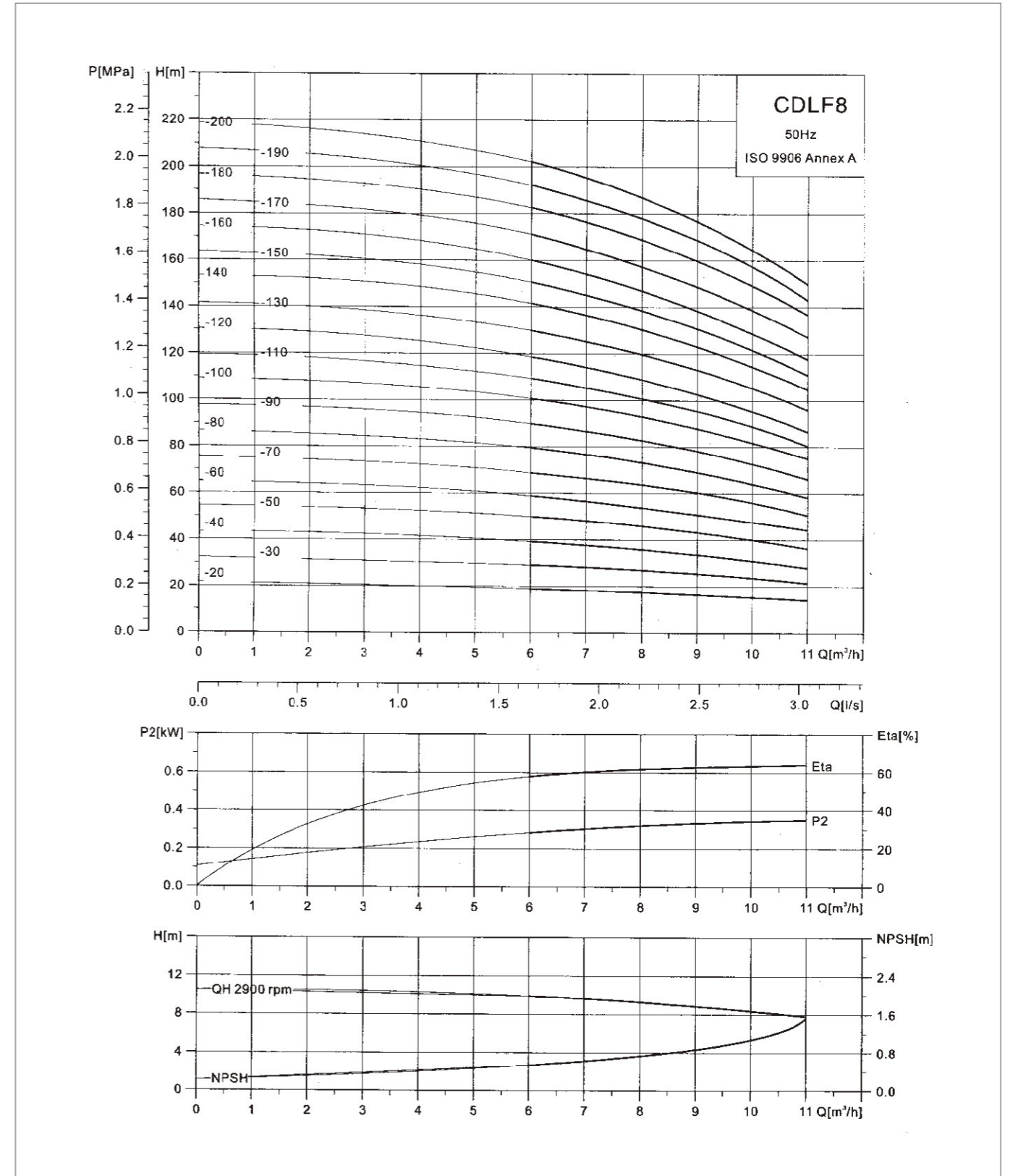

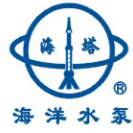

CDL、CDLF系列立式多级离心泵
CDL, CDLF series vertical multistage centrifugal pump

尺寸图

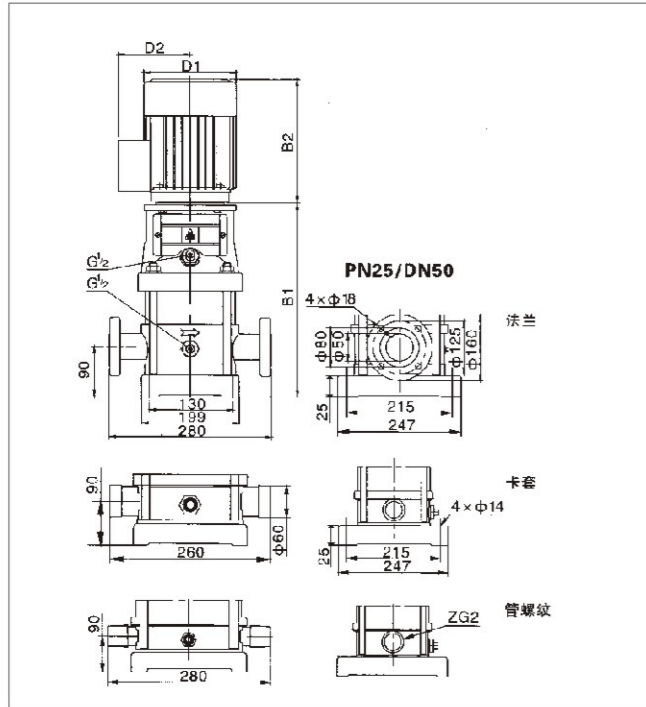

尺寸和重量

泵型号	尺寸 (mm)					重量 (kg)
	B1	B2	B1+B2	D1	D2	
CDLF16-20	414	290	704	190	155	51
CDLF16-30	469	315	784	197	165	54
CDLF16-40	514	335	849	230	188	60
CDLF16-50	579	430	1009	260	208	75
CDLF16-60	624		1054			80
CDLF16-70	669		1099			85
CDLF16-80	714		1144			88
CDLF16-90	789	490	1279	330	225	126
CDLF16-100	834		1324			126
CDLF16-110	879		1369			131
CDLF16-120	924		1414			131
CDLF16-130	969	1459	177			
CDLF16-140	1014	1504	177			
CDLF16-150	1059	1549	182			
CDLF16-160	1104	1594	182			

电气数据3x380-415v

泵型号	电机		功率因素COSφ
	千瓦kw	马力hp	
CDLF16-20	2.2	3.0	0.84
CDLF16-30	3.0	4.0	0.87
CDLF16-40	4.0	5.5	0.88
CDLF16-50	5.5	7.5	0.88
CDLF16-60	5.5	7.5	0.88
CDLF16-70	7.5	10	0.88
CDLF16-80	7.5	10	0.88
CDLF16-90	11	15	0.89
CDLF16-100	11	15	0.89
CDLF16-110	11	15	0.89
CDLF16-120	11	15	0.89
CDLF16-130	15	20	0.90
CDLF16-140	15	20	0.90
CDLF16-150	15	20	0.90
CDLF16-160	15	20	0.90

流量扬程

泵型号	流量Q (转数n≈2900)							
	M³/h	8	10	12	14	16	18	20
CDLF16-20	28	27	26	25	23	21	18	
CDLF16-30	42	41	39	37	35	32	27	
CDLF16-40	56	54	52	50	47	44	37	
CDLF16-50	69	68	65	62	59	54	47	
CDLF16-60	83	81	78	75	70	64	56	
CDLF16-70	97	95	92	87	82	75	68	
CDLF16-80	111	108	105	100	94	86	77	
CDLF16-90	125	122	118	112	106	97	88	
CDLF16-100	139	136	131	125	118	108	99	
CDLF16-110	153	149	144	137	129	129	108	
CDLF16-120	167	163	157	150	141	118	117	
CDLF16-130	180	176	170	162	153	141	128	
CDLF16-140	194	190	184	175	165	151	139	
CDLF16-150	208	203	197	187	177	162	148	
CDLF16-160	222	217	210	200	189	173	158	

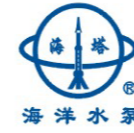

CDL、CDLF系列立式多级离心泵
CDL, CDLF series vertical multistage centrifugal pump

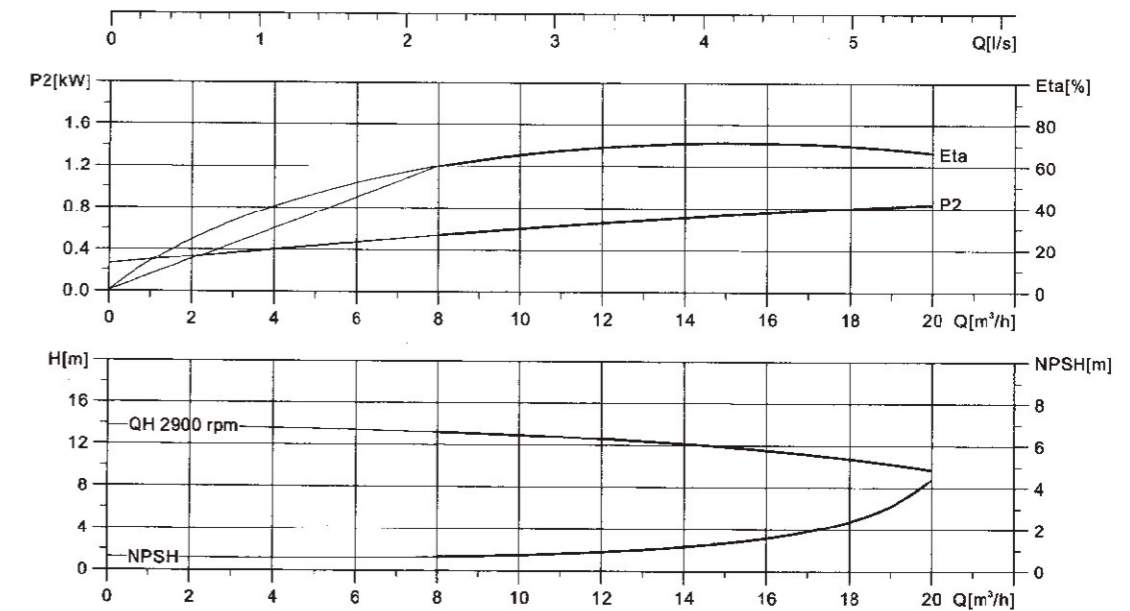
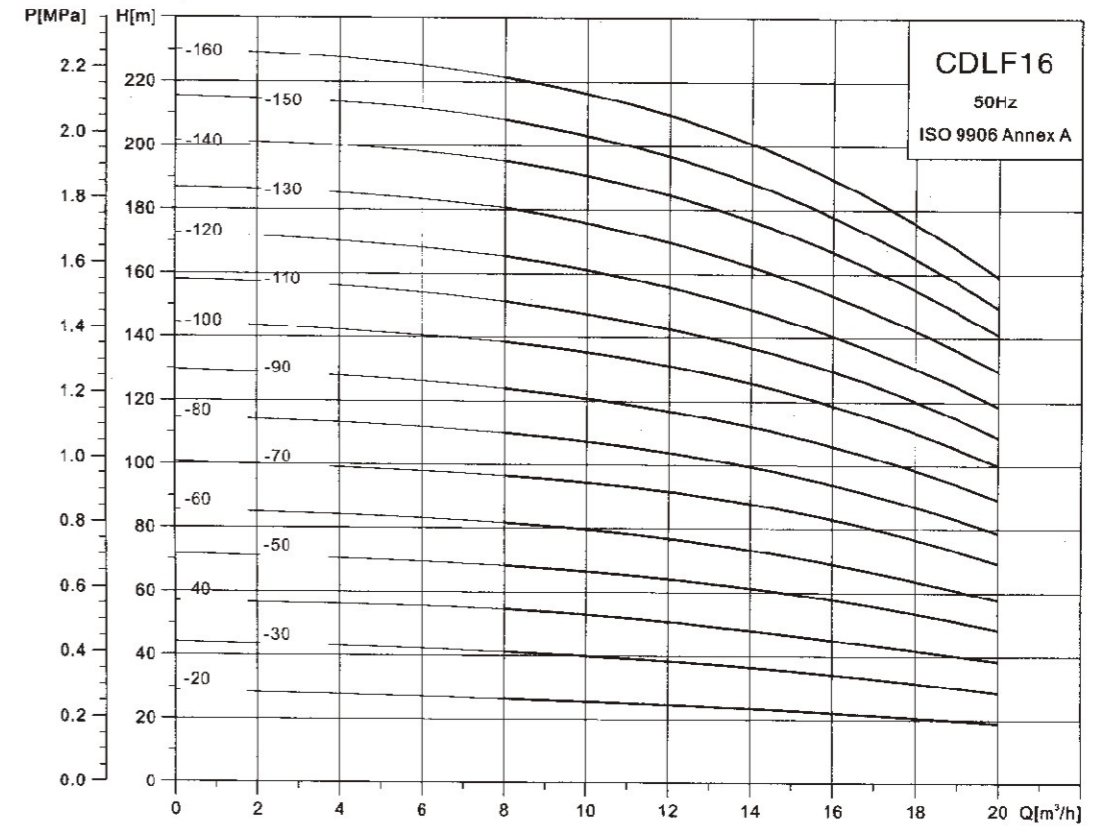

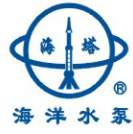

CDL、CDLF系列立式多级离心泵
CDL, CDLF series vertical multistage centrifugal pump

尺寸图

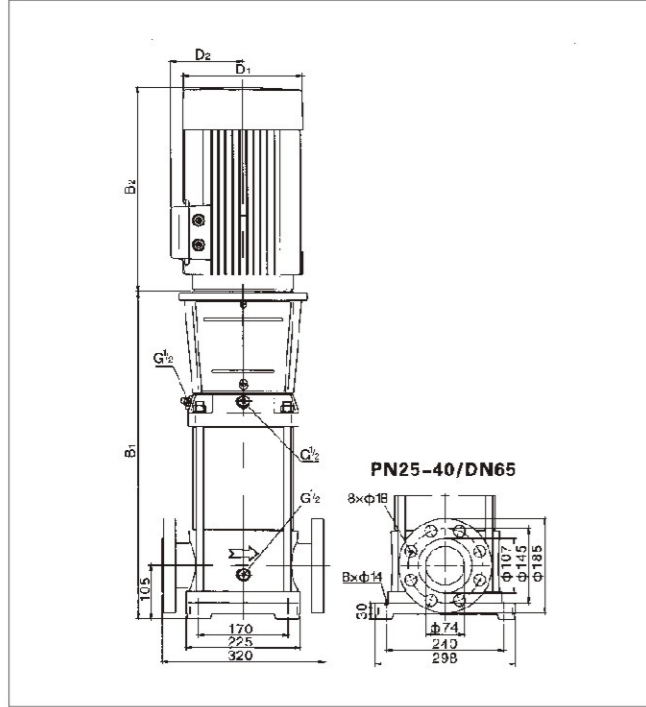

尺寸和重量

泵型号	尺寸 (mm)					重量 (kg)
	B1	B2	B1+B2	D1	D2	
CDLF32-10-1	505	290	795	190	155	70
CDLF32-10	505	290	795	190	155	71
CDLF32-20-1	575	315	890	197	165	80
CDLF32-20	575	335	910	230	180	82
CDLF32-30-1	645	430	1075	260	208	93
CDLF32-30	645		1075			94
CDLF32-40-1	715		1145			102
CDLF32-40	715		1145			103
CDLF32-50-1	895	490	1385	330	255	172
CDLF32-50	895		1385			173
CDLF32-60-1	965		1455			176
CDLF32-60	965		1455			177
CDLF32-70-1	1035	550	1525	330	255	188
CDLF32-70	1035		1525			189
CDLF32-80-1	1105		1595			192
CDLF32-80	1105		1595			193
CDLF32-90-1	1175	590	1725	360	285	218
CDLF32-90	1175		1725			219
CDLF32-100-1	1245		1795			222
CDLF32-100	1245		1795			223
CDLF32-110-1	1315	660	1905	400	310	259
CDLF32-110	1315		1905			260
CDLF32-120-1	1385		1975			263
CDLF32-120	1385		7975			264
CDLF32-130-1	1455	660	2115	400	310	327
CDLF32-130	1455		2115			328
CDLF32-140-1	1525		2185			331
CDLF32-140	1525		2185			332

电气数据3x380-415v

泵型号	电机		功率因素COSφ
	千瓦kw	马力hp	
CDLF32-10-1	1.5	2.0	0.84
CDLF32-10	2.2	3.0	0.84
CDLF32-20-1	3.0	4.0	0.87
CDLF32-20	4.0	5.5	0.88
CDLF32-30-1	5.5	7.5	0.88
CDLF32-30	5.5	7.5	0.88
CDLF32-40-1	7.5	10	0.88
CDLF32-40	7.5	10	0.88
CDLF32-50-1	11	15	0.89
CDLF32-50	11	15	0.89
CDLF32-60-1	11	15	0.89
CDLF32-60	11	15	0.89
CDLF32-70-1	15	20	0.90
CDLF32-70	15	20	0.90
CDLF32-80-1	15	20	0.90
CDLF32-80	15	20	0.90
CDLF32-90-1	18.5	25	0.90
CDLF32-90	18.5	25	0.90
CDLF32-100-1	18.5	25	0.90
CDLF32-100	18.5	25	0.90
CDLF32-110-1	22	30	0.90
CDLF32-110	22	30	0.90
CDLF32-120-1	22	30	0.90
CDLF32-120	22	30	0.90
CDLF32-130-1	30	40	0.90
CDLF32-130	30	40	0.90
CDLF32-140-1	30	40	0.90
CDLF32-140	30	40	0.90

流量扬程

泵型号	流量Q (转数n≈2900)							
	M³/h	16	20	24	28	32	36	40
CDLF32-10-1	14	13	12	11	9	7	4	
CDLF32-10	18	17	15	14	13	11	8	
CDLF32-20-1	29	28	26	23	20	16	11	
CDLF32-20	36	34	32	29	27	23	18	
CDLF32-30-1	47	44	41	38	33	28	21	
CDLF32-30	54	51	48	44	40	35	27	
CDLF32-40-1	65	62	58	53	46	40	30	
CDLF32-40	72	69	65	59	53	47	37	
CDLF32-50-1	83	79	74	68	60	52	41	
CDLF32-50	90	86	81	74	67	59	47	
CDLF32-60-1	101	97	90	83	74	65	51	
CDLF32-60	108	104	97	90	81	72	57	
CDLF32-70-1	119	114	107	98	88	78	60	
CDLF32-70	126	121	113	105	95	85	67	
CDLF32-80-1	136	131	123	114	102	90	71	
CDLF32-80	144	138	130	120	109	97	77	
CDLF32-90-1	154	148	140	129	117	102	82	
CDLF32-90	162	156	147	136	124	109	88	
CDLF32-100-1	175	166	157	146	131	115	91	
CDLF32-100	182	173	164	152	138	122	98	
CDLF32-110-1	193	184	173	164	146	128	102	
CDLF32-110	200	191	180	168	153	135	109	
CDLF32-120-1	211	201	189	178	160	140	113	
CDLF32-120	218	208	196	184	167	147	120	
CDLF32-130-1	230	218	206	193	174	153	124	
CDLF32-130	237	225	213	200	181	160	131	
CDLF32-140-1	247	235	222	210	189	165	135	
CDLF32-140	255	242	229	216	196	172	142	

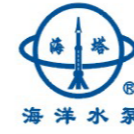

CDL、CDLF系列立式多级离心泵
CDL, CDLF series vertical multistage centrifugal pump

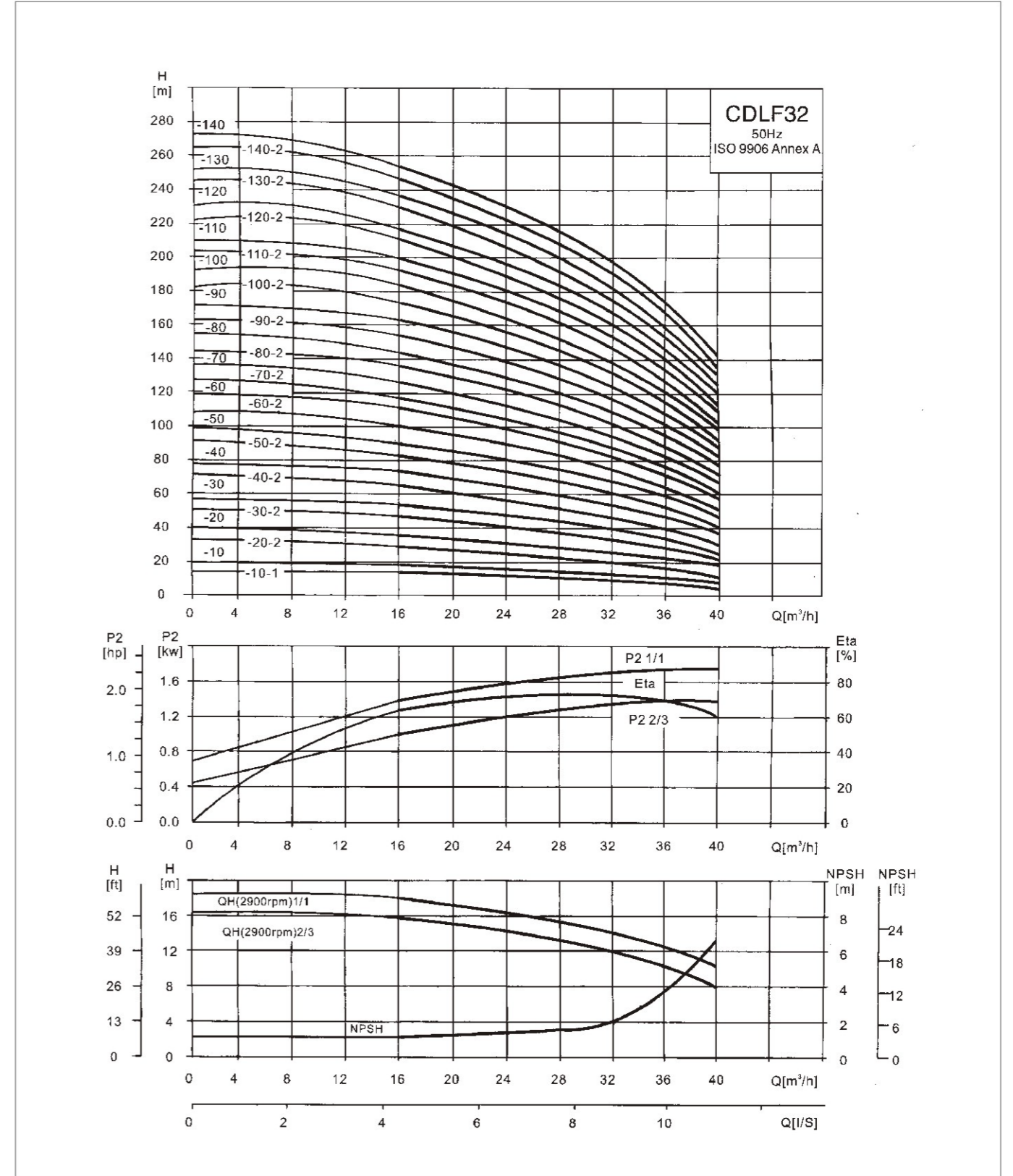

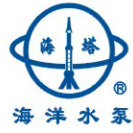

CDL、CDLF系列立式多级离心泵
CDL, CDLF series vertical multistage centrifugal pump

尺寸图

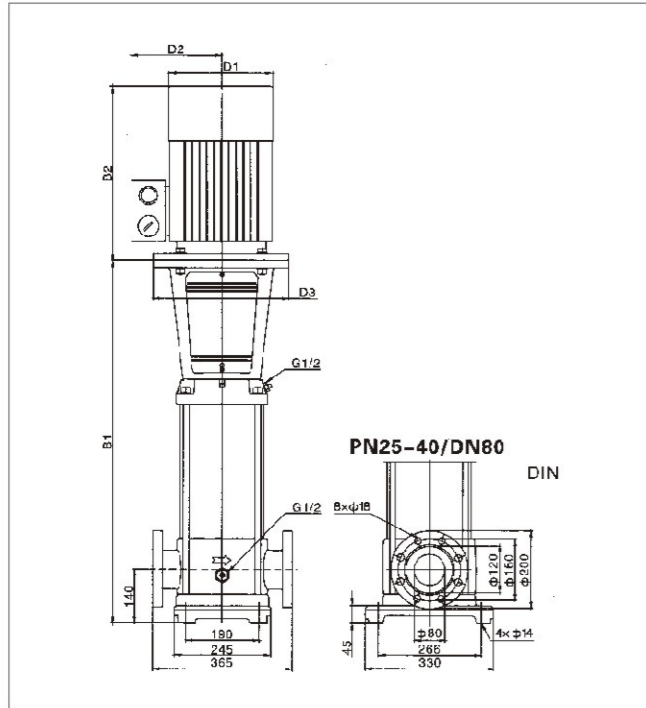

尺寸和重量

泵型号	尺寸 (mm)						重量 (kg)
	B1	B2	B1+B2	D1	D2	D3	
CDLF42-10-1	558	330	888	190	140	160	100
CDLF42-10				220	150		110
CDLF42-20-1	638	420	1058	260	210	300	120
CDLF42-20							125
CDLF42-30-1	828		1328				165
CDLF42-30		500		330	260		165
CDLF42-40-1	908		1408				205
CDLF42-40						350	205
CDLF42-50-1	988	550	1538				215
CDLF42-50				380	310		215
CDLF42-60-1	1068	600	1668				275
CDLF42-60							275
CDLF42-70-1	1148		1808				355
CDLF42-70							355
CDLF42-80-1	1228		1888				360
CDLF42-80		660		420	350	400	360
CDLF42-90-1	1308		1968				365
CDLF42-90							365
CDLF42-100-1	1388		2048				390
CDLF42-100							390
CDLF42-110-1	1468		2178				455
CDLF42-110							455
CDLF42-120-1	1556	710	2266	470	375	450	460
CDLF42-120							460
CDLF42-130	1636		2346				465

电气数据3x380-415v

泵型号	电机		功率因素COSφ
	千瓦kw	马力hp	
CDLF42-10-1	3.0	4.0	0.87
CDLF42-10	4.0	5.5	0.88
CDLF42-20-1	5.5	7.5	0.88
CDLF42-20	7.5	10	0.88
CDLF42-30-1	11	15	0.89
CDLF42-30	11	15	0.89
CDLF42-40-1	15	20	0.90
CDLF42-40	15	20	0.90
CDLF42-50-1	18.5	25	0.90
CDLF42-50	18.5	25	0.90
CDLF42-60-1	22	30	0.90
CDLF42-60	22	30	0.90
CDLF42-70-1	30	40	0.90
CDLF42-70	30	40	0.90
CDLF42-80-1	30	40	0.90
CDLF42-80	30	40	0.90
CDLF42-90-1	30	40	0.90
CDLF42-90	37	50	0.90
CDLF42-100-1	37	50	0.90
CDLF42-100	37	50	0.90
CDLF42-110-1	45	60	0.90
CDLF42-110	45	60	0.90
CDLF42-120-1	45	60	0.90
CDLF42-120	45	60	0.90
CDLF42-130	45	60	0.90

流量扬程

泵型号	流量Q (转数n≈2900)								
	M³/h	25	30	35	40	42	45	50	55
CDLF42-10-1	20	19	18	17	16	15	13	11	
CDLF42-10	24	23	22	21	20	19	18	16	
CDLF42-20-1	40	38	36	33	32	30	27	23	
CDLF42-20	48	46	44	42	41	39	35	31	
CDLF42-30-1	63	61	58	54	52	50	44	38	
CDLF42-30	71	69	66	63	61	58	53	47	
CDLF42-40-1	87	84	80	75	73	69	62	54	
CDLF42-40	95	92	88	84	81	78	71	62	
CDLF42-50-1	111	107	102	96	93	88	80	69	
CDLF42-50	119	115	110	105	101	97	88	78	
CDLF42-60-1	135	130	124	117	113	108	98	85	
CDLF42-60	143	138	132	125	122	116	106	93	
CDLF42-70-1	158	152	146	138	134	127	115	100	
CDLF42-70	166	161	154	146	142	135	124	109	
CDLF42-80-1	182	175	168	159	154	146	133	116	
CDLF42-80	190	184	176	167	162	154	141	124	
CDLF42-90-1	205	198	190	180	174	166	150	132	
CDLF42-90	214	207	198	188	183	174	159	140	
CDLF42-100-1	230	221	212	200	194	185	168	147	
CDLF42-100	238	230	220	209	203	193	177	155	
CDLF42-110-1	255	246	236	223	217	206	188	165	
CDLF42-110	263	255	244	232	225	214	196	173	
CDLF42-120-1	280	270	259	245	238	226	206	181	
CDLF42-120	289	280	268	255	247	236	216	190	
CDLF42-130	305	294	282	267	259	247	225	198	

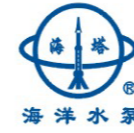

CDL、CDLF系列立式多级离心泵
CDL, CDLF series vertical multistage centrifugal pump

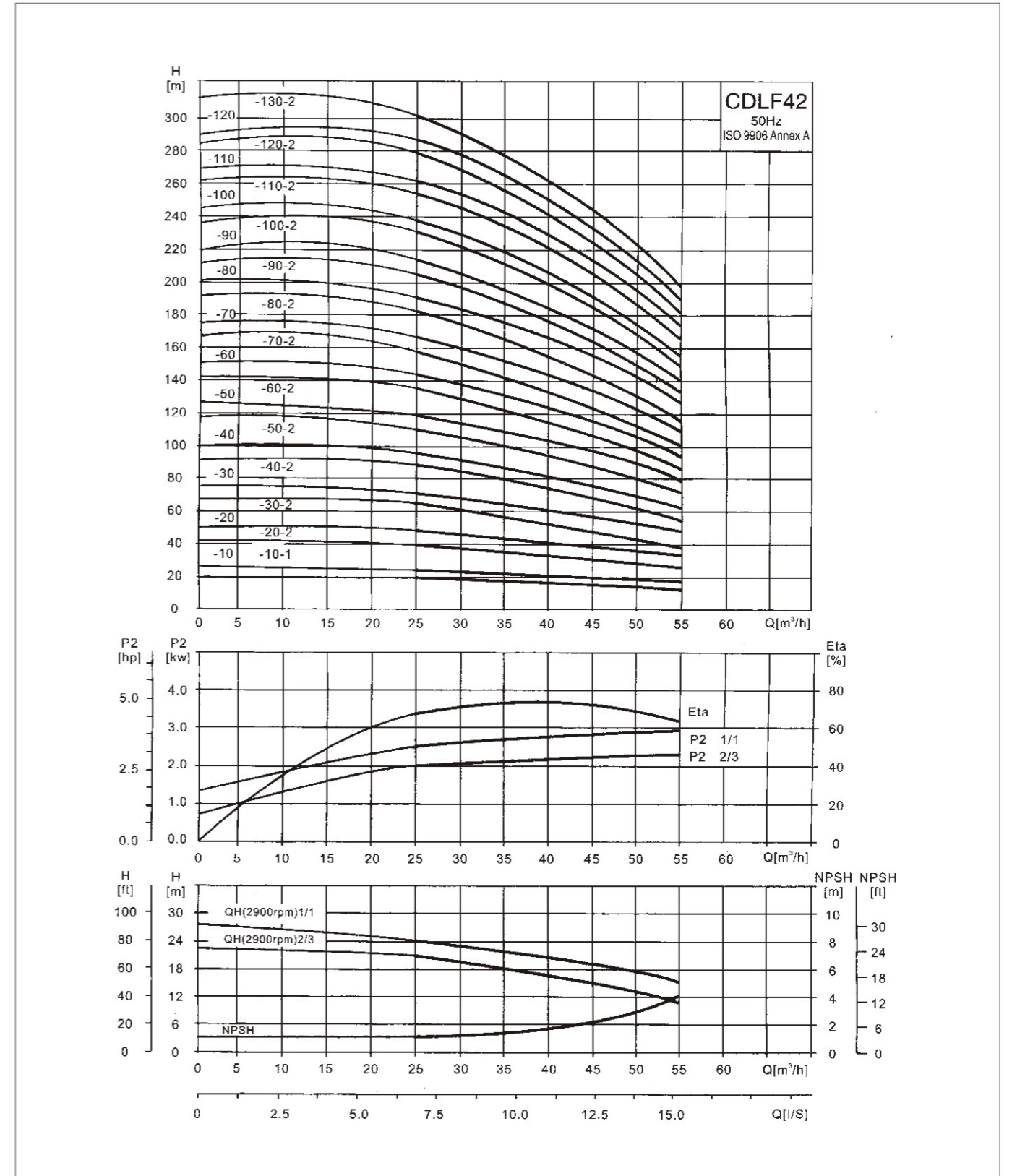

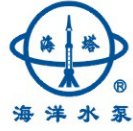

CDL、CDLF系列立式多级离心泵
CDL, CDLF series vertical multistage centrifugal pump

尺寸图

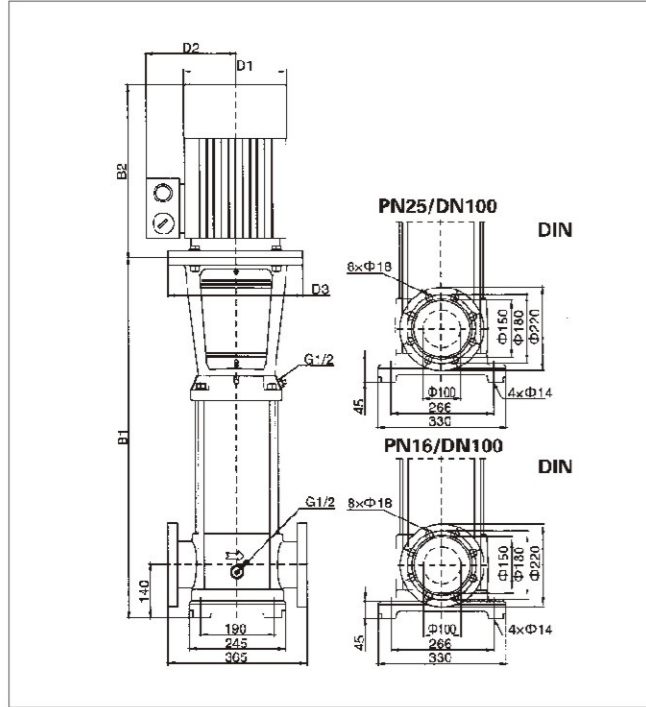

尺寸和重量

泵型号	尺寸 (mm)						重量 (kg)
	B1	B2	B1+B2	D1	D2	D3	
CDLF65-10-1	561	330	891	220	150	160	105
CDLF65-10			981	260	210	300	120
CDLF65-20-2	644	420	1064				130
CDLF65-20-1	754	500	1254	330	260	165	
CDLF65-20			1336			205	
CDLF65-30-2	836	550	1386	380	310	205	
CDLF65-30-1			1469			215	
CDLF65-30	919	600	1519	470	375	270	
CDLF65-40-2			1826			270	
CDLF65-40-1	1001	660	1661	420	350	350	
CDLF65-40			1744			350	
CDLF65-50-2	1084	710	1826	470	450	355	
CDLF65-50-1			1876			375	
CDLF65-50	1166	710	1958	470	450	375	
CDLF65-60-2			1876			380	
CDLF65-60-1	1248	710	1958	470	450	375	
CDLF65-60			1876			380	
CDLF65-70-2	1166	710	1876	470	450	380	
CDLF65-70-1			1958			445	
CDLF65-70	1248	710	1958	470	450	445	
CDLF65-80-2			1958			450	
CDLF65-80-1	1958	450					

电气数据3x380-415v

泵型号	电机		功率因素COSφ
	千瓦kw	马力hp	
CDLF65-10-1	4.0	5.5	0.88
CDLF65-10	5.5	7.5	0.88
CDLF65-20-2	7.5	10	0.88
CDLF65-20-1	11	15	0.89
CDLF65-20	11	15	0.89
CDLF65-30-2	15	20	0.90
CDLF65-30-1	15	20	0.90
CDLF65-30	18.5	25	0.90
CDLF65-40-2	18.5	25	0.90
CDLF65-40-1	22	30	0.90
CDLF65-40	22	30	0.90
CDLF65-50-2	30	45	0.90
CDLF65-50-1	30	40	0.90
CDLF65-50	30	40	0.90
CDLF65-60-2	30	40	0.90
CDLF65-60-1	37	50	0.90
CDLF65-60	37	50	0.90
CDLF65-70-2	37	50	0.90
CDLF65-70-1	37	50	0.90
CDLF65-70	45	60	0.90
CDLF65-80-2	45	60	0.90
CDLF65-80-1	45	60	0.90

流量扬程

泵型号	流量Q (转数n≈2900)	扬程H (M)							
		M³/h	30	40	50	60	65	70	80
CDLF65-10-1	19	18	16	14	13	11	8		
CDLF65-10	27	25	23	21	20	18	15		
CDLF65-20-2	39	36	33	29	26	23	17		
CDLF65-20-1	46	44	40	36	33	30	24		
CDLF65-20	53	51	47	43	40	37	30		
CDLF65-30-2	66	62	56	50	46	41	32		
CDLF65-30-1	73	69	63	57	53	48	39		
CDLF65-30	80	76	70	64	60	55	46		
CDLF65-40-2	92	87	80	71	66	60	47		
CDLF65-40-1	100	94	87	78	73	67	54		
CDLF65-40	107	101	94	85	80	74	61		
CDLF65-50-2	121	114	105	95	88	80	64		
CDLF65-50-1	128	121	112	102	95	87	71		
CDLF65-50	136	129	119	109	102	94	78		
CDLF65-60-2	150	142	131	118	110	101	81		
CDLF65-60-1	157	149	138	125	117	108	88		
CDLF65-60	164	156	145	132	124	115	95		
CDLF65-70-2	179	169	156	141	132	121	99		
CDLF65-70-1	186	176	163	148	139	128	106		
CDLF65-70	193	183	170	155	146	135	112		
CDLF65-80-2	207	196	182	164	154	142	116		
CDLF65-80-1	215	203	189	171	161	149	123		



CDL、CDLF系列立式多级离心泵
CDL, CDLF series vertical multistage centrifugal pump

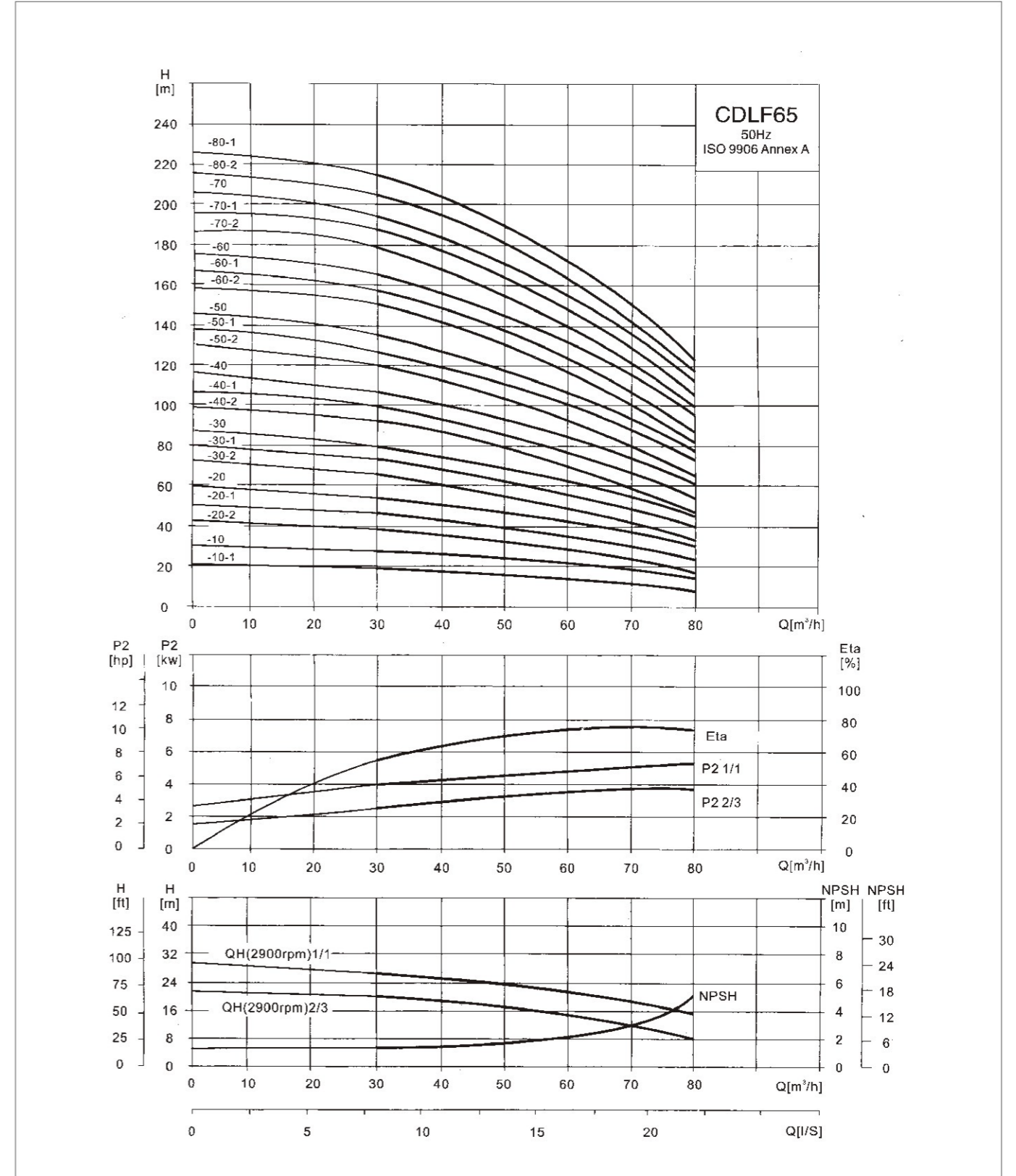

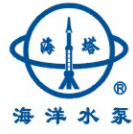

CDL、CDLF系列立式多级离心泵
CDL, CDLF series vertical multistage centrifugal pump

尺寸图

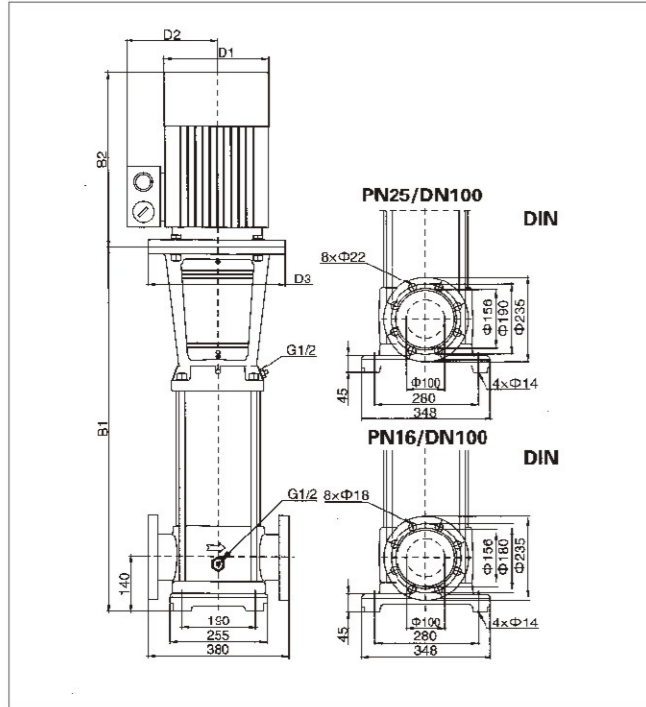

尺寸和重量

泵型号	尺寸 (mm)						重量 (kg)
	B1	B2	B1+B2	D1	D2	D3	
CDLF85-10-1	571	420	991	260	210	300	125
CDLF85-10							130
CDLF85-20-1	773	500	1273	330	260	350	170
CDLF85-20							205
CDLF85-30-1	865	550	1415	380	260		220
CDLF85-30		600	1465				270
CDLF85-40-1	957	660	1617	420	350	400	355
CDLF85-40							355
CDLF85-50-1	1049	660	1709				380
CDLF85-50							380
CDLF85-60-1	1141	710	1851	470	375	450	445
CDLF85-60							445

电气数据3x380-415v

泵型号	电机		功率因素COSφ
	千瓦kw	马力hp	
CDLF85-10-1	5.5	7.5	0.88
CDLF85-10	7.5	10	0.88
CDLF85-20-1	11	15	0.89
CDLF85-20	15	20	0.90
CDLF85-30-1	18.5	25	0.90
CDLF85-30	22	30	0.90
CDLF85-40-1	30	40	0.90
CDLF85-40	30	40	0.90
CDLF85-50-1	37	50	0.90
CDLF85-50	37	50	0.90
CDLF85-60-1	45	60	0.90
CDLF85-60	45	60	0.90

流量扬程

泵型号	流量Q (转数n≈2900)								
	M³/h	50	60	70	80	85	90	100	110
CDLF85-10-1		22	19	17	16	14	13	10	6
CDLF85-10		25	24	22	21	20	19	16	12
CDLF85-20-1		41	39	36	32	30	28	22	15
CDLF85-20		53	50	47	44	41	40	36	30
CDLF85-30-1		68	65	60	55	52	49	41	32
CDLF85-30	扬程 H (M)	81	77	72	67	64	62	55	48
CDLF85-40-1		98	93	87	80	75	72	62	50
CDLF85-40		110	105	100	92	86	84	76	66
CDLF85-50-1		126	120	113	104	98	93	81	68
CDLF85-50		139	131	124	115	110	106	94	83
CDLF85-60-1		155	148	139	129	122	117	102	86
CDLF85-60		168	160	150	141	134	130	117	103

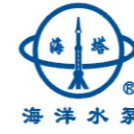

CDL、CDLF系列立式多级离心泵
CDL, CDLF series vertical multistage centrifugal pump

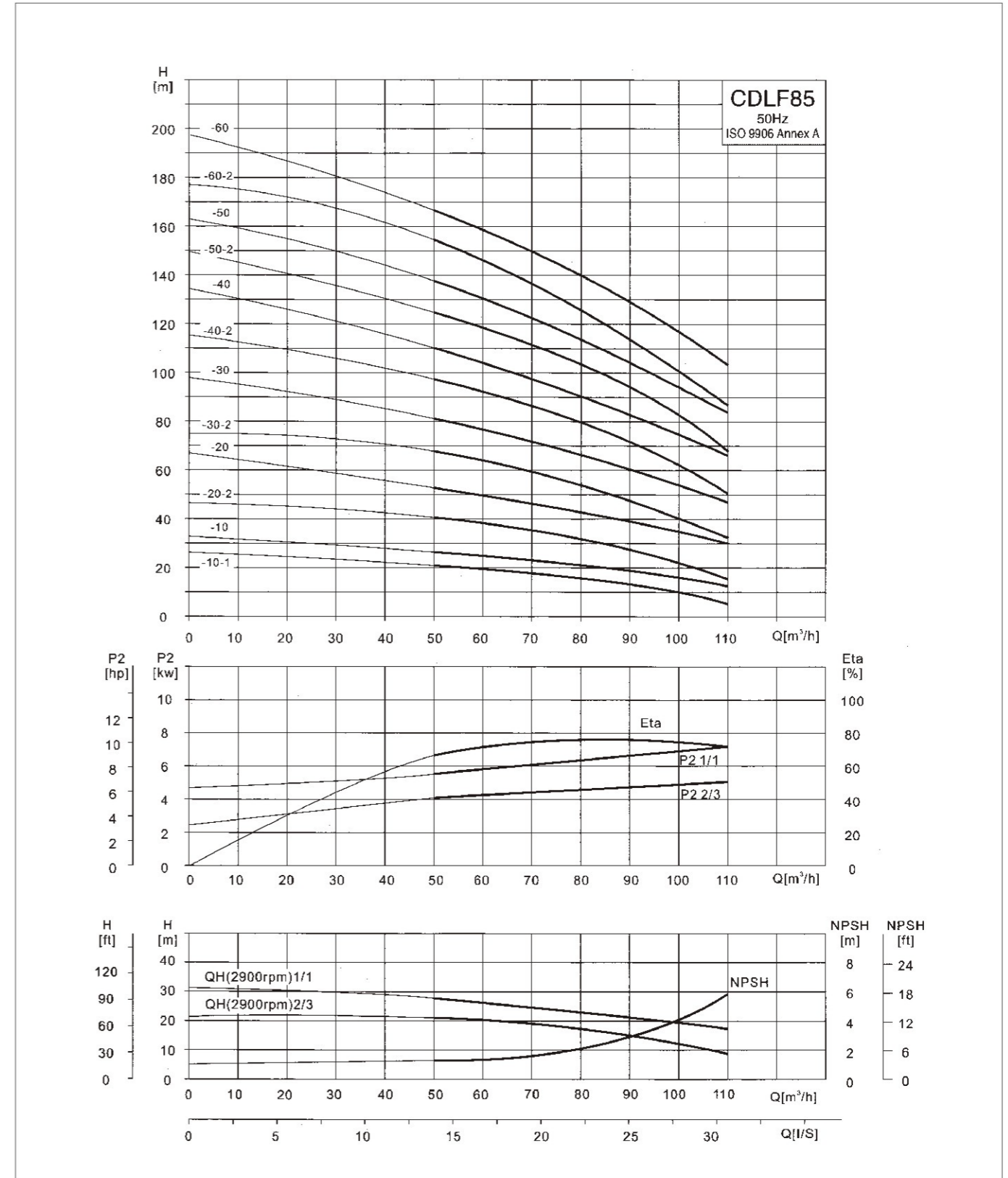



CDL、CDLF系列立式多级离心泵
CDL, CDLF series vertical multistage centrifugal pump

尺寸图

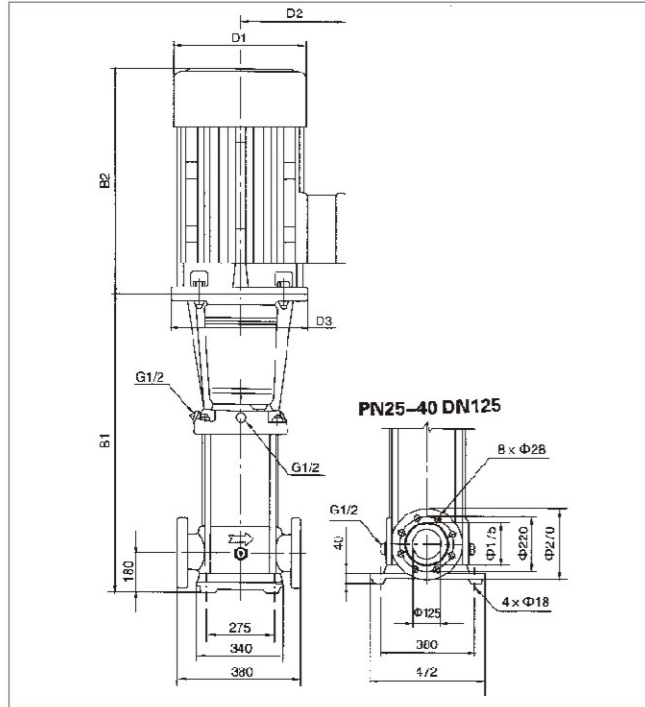

尺寸和重量

泵型号	尺寸 (mm)						重量 (kg)
	B1	B2	B1+B2	D1	D2	D3	
CDLF120-10	840		1330				230
CDLF120-20-2		490	1490	330	255	350	245
CDLF120-20-1	1000	550	1550				250
CDLF120-20		590	1590	360	285		285
CDLF120-30-2							360
CDLF120-30-1	1160	600	1820	400	310	400	360
CDLF120-30							360
CDLF120-40-2			1980				400
CDLF120-40-1	1320						400
CDLF120-40			2020				460
CDLF120-50-2		700		460	340	450	470
CDLF120-50-1	1480		2180				470
CDLF120-50			2280				575
CDLF120-60-2		770		540	370		585
CDLF120-60-1	1670		2440				585
CDLF120-60			2515			550	705
CDLF120-70-2		845		580	410		715
CDLF120-70-1	1830		2675				715
CDLF120-70							715

电气数据3x380-415v

泵型号	电机		功率因素COSφ
	千瓦kw	马力hp	
CDLF120-10	11	15	0.89
CDLF120-20-2	15	20	0.9
CDLF120-20-1	18.5	25	0.9
CDLF120-20	22	30	0.9
CDLF120-30-2	30	40	0.9
CDLF120-30-1	30	40	0.9
CDLF120-30	30	40	0.9
CDLF120-40-2	37	50	0.9
CDLF120-40-1	37	50	0.9
CDLF120-40	45	60	0.9
CDLF120-50-2	45	60	0.9
CDLF120-50-1	45	60	0.9
CDLF120-50	55	75	0.9
CDLF120-60-2	55	75	0.9
CDLF120-60-1	55	75	0.9
CDLF120-60	75	101	0.9
CDLF120-70-2	75	101	0.9
CDLF120-70-1	75	101	0.9
CDLF120-70	75	10	0.9

流量扬程

泵型号	流量Q (转数n≈2900)										
	M³/h	60	70	80	90	100	110	120	130	140	150
CDLF120-10	22	21.8	21.6	21	20.5	19.5	18	17	16	15	
CDLF120-20-2	34	33.6	33	31	30.2	30	28	27	25	24	
CDLF120-20-1	41	40	39.5	38.5	37	36.5	35	32.5	30	27.5	
CDLF120-20	46	45	44.5	43.5	42.4	41	40	38	36	33.5	
CDLF120-30-2	57	56	55	53.5	52	51	49	46.5	43.5	41	
CDLF120-30-1	64	63	62	60	58.5	57.5	56	52	49	46	
CDLF120-30	69.5	68.5	67.5	66	64.4	62.5	61	57.5	54.5	51	
CDLF120-40-2	80.5	79	78	76	73.5	72	69	66	61.5	58	
CDLF120-40-1	87	86	84.5	82	80	78	76	72	68	64.5	
CDLF120-40	92.5	91	90	88	85.5	83	81	77	73	68.5	
CDLF120-50-2	104.5	103	101	99	96	93	90	85.5	80.5	75.5	
CDLF120-50-1	110.5	109	107.5	105	102	100	97	92	86.5	83	
CDLF120-50	115.5	114	113	110	107.5	104.5	102	96	91	86	
CDLF120-60-2	128	125.5	123	121	117.3	113.5	110	104.5	98.5	92.5	
CDLF120-60-1	123.4	132	130.5	127	124	121	119	111	105	100	
CDLF120-60	139	137	135	132	128.8	126	123	116	110	104	
CDLF120-70-2	151	148	145.5	143	138.6	134	130	123.5	116.5	109	
CDLF120-70-1	156.5	154	152	148.5	144.5	141	138	130	123	116.5	
CDLF120-70	162.5	160.5	158.5	155	155	148	145	137	129	123	

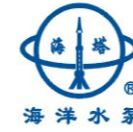

CDL、CDLF系列立式多级离心泵
CDL, CDLF series vertical multistage centrifugal pump

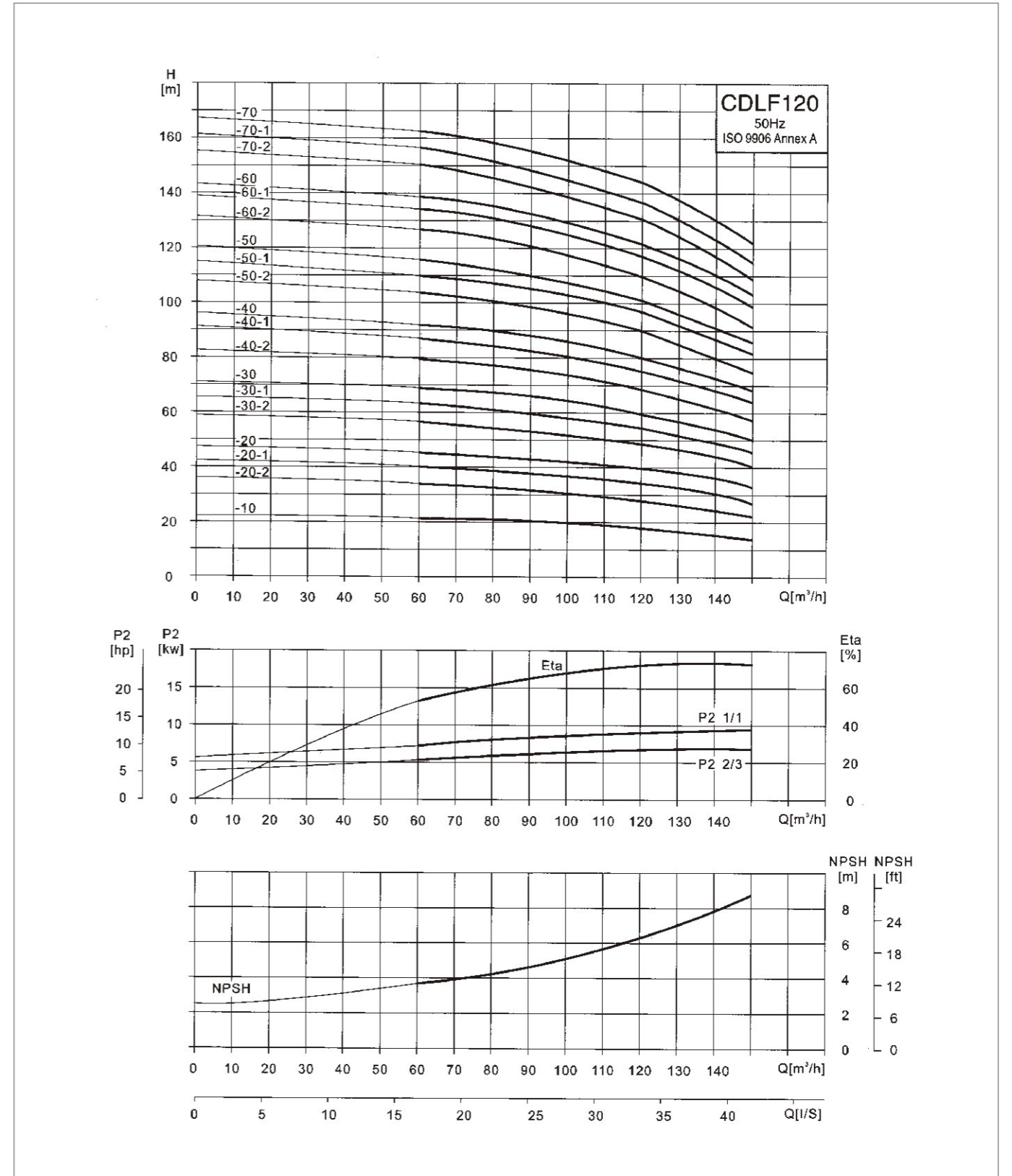

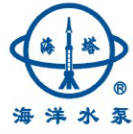

CDL、CDLF系列立式多级离心泵
CDL, CDLF series vertical multistage centrifugal pump

尺寸图

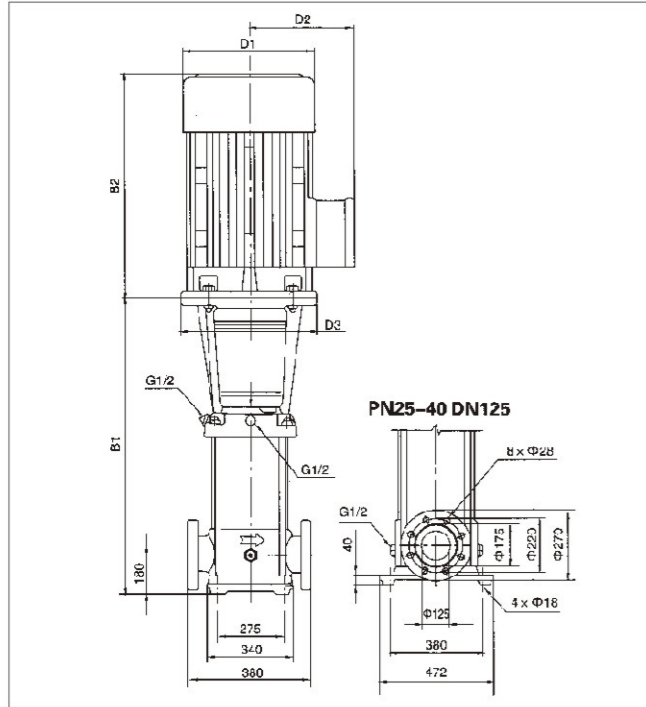

尺寸和重量

泵型号	尺寸 (mm)						重量 (kg)
	B1	B2	B1+B2	D1	D2	D3	
CDLF150-10-1	840	490	1330	330	255	350	230
CDLF150-10							235
CDLF150-20-2	1000	590	1590	360	285		250
CDLF150-20-1							295
CDLF150-20	1160	600	1660	400	310	400	350
CDLF150-30-2							360
CDLF150-30-1	1320	700	2020	460	340	450	360
CDLF150-30							385
CDLF150-40-2	1350	770	2120	540	370		460
CDLF150-40-1							460
CDLF150-40	1510	845	2280	580	410	550	560
CDLF150-50-2							570
CDLF150-50-1	1670	845	2355	580	410	550	690
CDLF150-50							690
CDLF150-60-2	1670	845	2515	580	410	550	700
CDLF150-60-1							700
CDLF150-60							700

电气数据3x380-415v

泵型号	电机		功率因素COSφ
	千瓦kw	马力hp	
CDLF150-10-1	11	15	0.89
CDLF150-10	15	20	0.9
CDLF150-20-2	18.5	25	0.9
CDLF150-20-1	22	30	0.9
CDLF150-20	30	40	0.9
CDLF150-30-2	30	40	0.9
CDLF150-30-1	37	50	0.9
CDLF150-30	37	50	0.9
CDLF150-40-2	45	60	0.9
CDLF150-40-1	45	60	0.9
CDLF150-40	55	75	0.9
CDLF150-50-2	55	75	0.9
CDLF150-50-1	75	101	0.9
CDLF150-50	75	101	0.9
CDLF150-60-2	75	101	0.9
CDLF150-60-1	75	101	0.9
CDLF150-60	75	101	0.9

流量扬程

泵型号	流量Q (转数n≈2900)											
	M³/h	80	90	100	110	120	130	140	150	160	170	180
CDLF150-10-1	18.3	17.8	17.3	17	16	15	14	13	11	10	8.5	
CDLF150-10	24	23	22.5	22	21.5	20.5	20	19	17	16	15	
CDLF150-20-2	37	35.5	34	33	32	31	29	28	26	23	21	
CDLF150-20-1	44.3	43	42	40	39	38.5	37.5	35	33	30	27	
CDLF150-20	50	49	48	47	45.5	44	42	40	37	34	32	
CDLF150-30-2	63.5	61	59	57.5	56	54.5	53	49	45.5	42	39	
CDLF150-30-1	70	68	67	65	63	62	60	56	53	49	45	
CDLF150-30	78	76.5	75	73	70.5	68	66	63	59	55	50.5	
CDLF150-40-2	89	87	84	81.5	79	77	74.5	71	65.5	60	56	
CDLF150-40-1	96.5	94	91.5	89	86.5	84	81.5	77	72.5	67	62	
CDLF150-40	104	102	100	97	95	91	88	84	79.5	74	68	
CDLF150-50-2	115.5	112	109	106	102.5	100	97	92	86	79	73.5	
CDLF150-50-1	122.5	119.5	117	113.5	111.5	107.5	104.5	99	93.5	87	80	
CDLF150-50	130	127.5	125	121	119	115	111.5	107	101	94.5	86.5	
CDLF150-60-2	140	137	133	130	126	121	118	106	106	98	91	
CDLF150-60-1	148.5	145	141.7	137.5	135	131	127	114.5	114.5	106.5	97.5	
CDLF150-60	157	153	149	145	142	139.5	137	123.5	123.5	116	109	



CDL、CDLF系列立式多级离心泵
CDL, CDLF series vertical multistage centrifugal pump

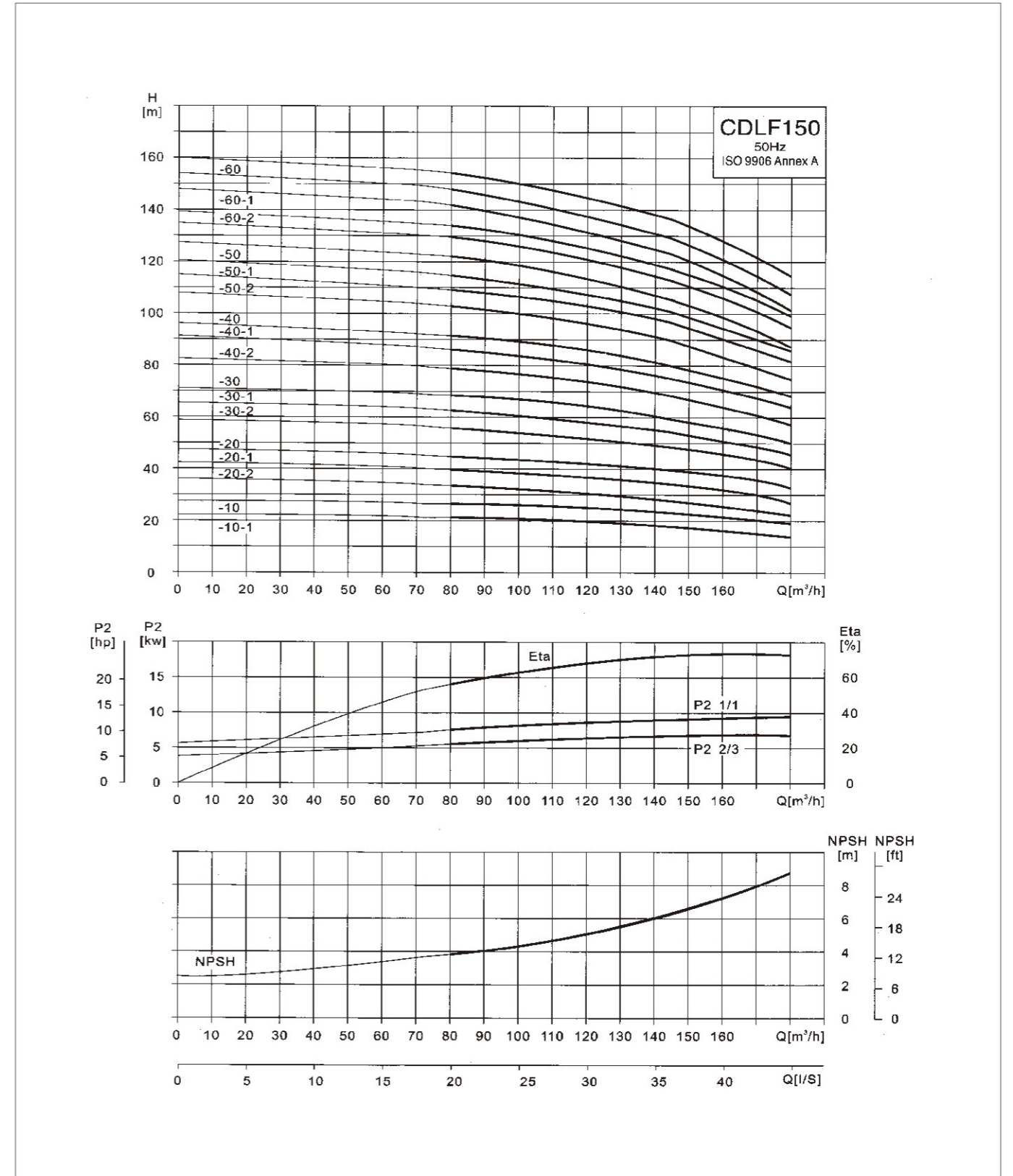



CDL、CDLF系列立式多级离心泵
CDL, CDLF series vertical multistage centrifugal pump

尺寸图

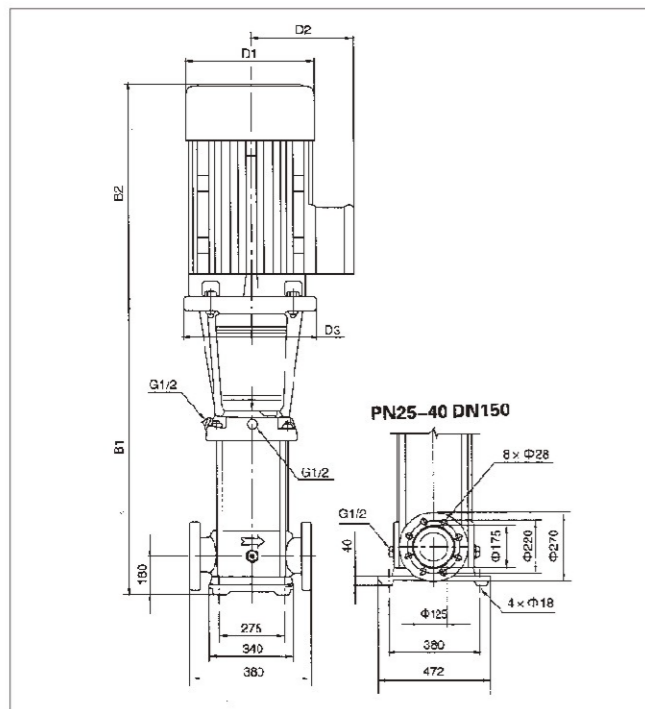

尺寸和重量

泵型号	尺寸 (mm)						重量 (kg)
	B1	B2	B1+B2	D1	D2	D3	
CDLF200-10-B	907	550	1457	330	255	350	311
CDLF200-10-A		590	1497	360	285		347
CDLF200-10	1101	660		1567	400	400	403
CDLF200-20-2B		1761		310	447		
CDLF200-20-2A	1131	700	1801	460	340	450	504
CDLF200-20-A		770		1901	540		370
CDLF200-20	1325	770		1901	540	550	595
CDLF200-30-2B		845		2170	580		410
CDLF200-30-A-B	1519	845		2170	580	550	748
CDLF200-30-2A		895		2220	817		
CDLF200-30-B	1519	895		2220	817	660	830
CDLF200-30-A		2414		1180			
CDLF200-40-2B	1519	895		2220	817	660	1180
CDLF200-40-2A		1140		2659	645		550
CDLF200-40-A	1519	1140		2659	645	660	1180
CDLF200-40		1140		2659	645		660

电气数据3x380-415v

泵型号	电机		功率因素COSφ
	千瓦kw	马力hp	
CDLF200-10-B	18.5	25	0.89
CDLF200-10-A	22	30	0.9
CDLF200-10	30	40	0.9
CDLF200-20-2B	37	50	0.9
CDLF200-20-2A	45	60	0.9
CDLF200-20-A	55	75	0.9
CDLF200-20	55	75	0.9
CDLF200-30-2B	75	101	0.9
CDLF200-30-A-B	75	101	0.9
CDLF200-30-2A	75	101	0.9
CDLF200-30-B	75	101	0.9
CDLF200-30-A	75	101	0.9
CDLF200-30	90	120	0.9
CDLF200-40-2B	90	120	0.9
CDLF200-40-2A	110	150	0.9
CDLF200-40-A	110	150	0.9
CDLF200-40	110	150	0.9

流量扬程

泵型号	流量Q (转数n≈2900)								
	M³/h	100	120	140	160	180	200	220	240
CDLF200-10-B	22.5	25	24	23	21.5	20	18	15.5	
CDLF200-10-A	29	28.5	27.5	26.5	25.5	24	22	20	
CDLF200-10	38.5	38	37.5	36.5	35	34	32.5	30	
CDLF200-20-2B	53	51	49	47	44	41	37	32	
CDLF200-20-2A	59.5	58	56	54	52.5	49	44.5	40.5	
CDLF200-20-A	69	68	66	64	62	59	55.5	51	
CDLF200-20	78.5	77.5	76	74	71.5	69	66	61.5	
CDLF200-30-2B	91.5	89	86.5	83.5	79	75	70	63	
CDLF200-30-A-B	95	93	90	87	83.5	79	73.5	67	
CDLF200-30-2A	99.5	97.5	94.5	91.5	89	84	78.5	72	
CDLF200-30-B	104.5	102.5	100	97	93	89	84.5	77.5	
CDLF200-30-A	108	106	103.5	100.5	97.5	93	88	81.5	
CDLF200-30	117.5	116	113.5	110.5	107	103	99	92	
CDLF200-40-2B	131.5	129	125.5	121	115	110	103.5	94	
CDLF200-40-2A	138.5	136	132	128	124	118	111	102.5	
CDLF200-40-A	148	145.5	142.5	138	134	128	122	113	
CDLF200-40	157.5	155.5	152.5	148	143.5	138	132.5	123.5	

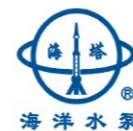

CDL、CDLF系列立式多级离心泵
CDL, CDLF series vertical multistage centrifugal pump

